

43 BUG KILLERS

Antimicrobial and antiviral coatings surge during pandemic

57 STACK TESTING

Keeping plating air pollutants in check



CFCM

CANADIAN FINISHING & COATINGS MANUFACTURING MAGAZINE

AEROSPACE COATINGS TAKE OFF

**CORPORATE
PROFILE
ISSUE**





Protect your Coatings from Microbial Attack with Azelis

Azelis Canada provides high-performance innovative solutions and specialty materials for the CASE industry. We offer an extensive listing of Resins, Additives, Pigments, Diluents, Elastomers, Epoxies, Biocides and Lab supplies.

Our portfolio of Biocides keeps your product protected from microbial attack, whether at the stages of formulation or at final application, Azelis ensures the vital protection needed to keep your product at optimum performance through challenge testing and microbial problem resolution.

We also provide solutions for Rubber and Plastics, Essential Chemicals, Inks and Construction Industries.

Please contact your local Azelis representative to learn how you can put the advanced power of Azelis to work for you.

Azelis Canada
An Azelis Americas Company

1570 Ampère, Suite 106
Boucherville, QC, J4B 7L4

106 Summerlea Rd
Brampton, ON L6T 4X3

Visit www.azeliscanada.com
E-mail : ca-info@azelis.com

235 Advance Blvd
Brampton, ON L6T 4J2

**Innovation
through
formulation**



Azelis Canada provides our customer with superior solutions through our technical services, product selection and marketing expertise. Our CASE portfolio serves the industrial, architectural, adhesives, sealants, construction, inks and elastomers industries and offers an extensive product listing of Resins, Additives, Pigments, Diluents, Elastomers, Epoxies and Biocides.

Azelis is a global leader in application labs; over 60 application labs across the world, each dedicated to a single market segment, where we develop innovative formulations that excite our customers. Our award-winning teams work with both suppliers and customers to create market solutions that set them apart.

Some of the services Azelis CASE Laboratories (located in Atlanta and Wisconsin) offers are: Custom formulations, product testing, regulatory compliance, and sales support.

Azelis has been awarded with the Gold rating from EcoVadis. EcoVadis is the world's most trusted provider of business sustainability ratings, intelligence and

collaborative performance improvement tools for global supply chain.

Azelis' Corporate Social Responsibility performance is assessed by EcoVadis on four pillars: environment, labor and human rights, ethics and sustainable procurement.

At Azelis, we believe that Corporate Social Responsibility and a sustainable business model will enable us to continue doing business in the long term, with sustainable innovation at the center of our business model.

Azelis is also a member of Together for Sustainability, a global initiative from the chemical industry for sustainable supply chains. This membership enables us to further improve our standard, with the goal of becoming the global benchmark for sustainability in the industry of specialty chemicals distribution.

We also provide innovative solutions to the Rubber and Plastics and Essential Chemicals Industries.



Meeting Mixing and Blending Needs for More than Half a Century

Conn and Company, headquartered in Warren, PA, has been designing and manufacturing industrial mixing equipment for more than 60 years.

The Conn Blades

Conn and Company recognized the

need for blending blades and dispersion blades that provided true pumping action instead of plowing action. The company has brought four patented blades to the market under the trade name Conn Blade®.

The ITT style blade has a combina-

tion of louvers and teeth. It is a high pumping high shear dispersion blade and is the most efficient and aggressive dispersion blade available.

The IT style has the louvers providing superior pumping action, but without the teeth. It is a high pumping, low shear, blending blade and is excellent for mixing micro spheres or flakes or other fillers that need to be well mixed, but not destroyed.

The ITC CONN Blade® is an eight-vane open style blade providing excellent material flow, with more shear than the IT, but is not as aggressive as the ITT.

The patented P-ITT CONN Blade® is of UHMW Polyethylene and is excellent for highly corrosive or highly abrasive mixing. The P-ITT CONN Blade® is the most efficient and aggressive polyethylene blade available.

The Conn blades are available from 2" diameter to 48" diameter with mounting holes or mounting hubs to retrofit and upgrade a customer's existing equipment. Split construction is available for entry through manways. Conn also manufactures complete units and drive assemblies to mount on your tanks. Conn supplies air or electric utility/laboratory mixers, spool-type top entry for flange mounting to the customer's tank, and drive assemblies for mounting on bridge support for open top tanks. Conn and Company just needs the customer's requirements and will be happy to be of assistance.

Conn handles all worldwide sales from the home office in Warren, PA.

Contact Richard C. Freeman at:

rcfreeman@connblade.com
T (814) 723-7980 or fax 814-723-8502
www.connblade.com

THE CONN BLADE®

Patented blending/dispersing blade design makes radical improvement over old saw tooth designs

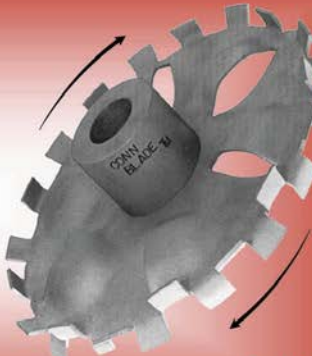
POLYETHYLENE
STAINLESS

- * Most efficient and aggressive blending/dispersing blade available.
- * Provides proper combination of pumping action and shear/dispersion essential for fast consistent results.
- * Built in pumping action cuts processing time.
- * Longer life due to heavier gauge construction.
- * Less heat due to shorter required running time.
- * Excellent for high or low speed and high or low viscosity.
- * Supplied with hubs or mounting holes required to retrofit and upgrade present equipment.
- * Pumping blades without teeth are available and are excellent for gentle blending and agitation.

DESIGNERS AND MANUFACTURERS OF INDUSTRIAL MIXING EQUIPMENT

Since 1948

CONN AND Co., L.L.C.



Stirrers Or Complete Units For:

PAINTS	URETHANE FOAMS
ADHESIVES	SLURRIES
INKS	GROUTS
CEMENTS	ETC. . . .

www.connblade.com

11 SOUTH MARION STREET • WARREN, PENNA. 16365 • PHONE 814/723-7980

FAX (814) 723-8502
6

Volume 15 Number 1**EDITOR**

Theresa Rogers
416-201-1975
theresa.rogers@cfcfm.ca

SENIOR EDITOR

Edward Mason
edward.mason@cfcfm.ca

CONTRIBUTORS

Alexander Hunger, Michael Kelly,
Gary LeRoux, Peter Paine,
Robert Ravensbergen, Bob Smith

FOUNDING PUBLISHER

Pete Wilkinson

ASSOCIATE PUBLISHER & SALES

Gillian Thomas
416-277-1269
gillian.thomas@cfcfm.ca

GRAPHIC DESIGN

Allan S. Bates
Green Apple Prepress
katobatz@teksavvy.com

CFCM Canadian Finishing & Coatings Manufacturing is published bi-monthly by Wilkinson Media Canada Inc. Subscriptions are free to qualified Canadian finishers and coatings manufacturers and their suppliers. Subscriptions (six issues): Canada \$60.00 per year plus taxes (GST #858877210 RT0001). United States U.S. \$57.00. Foreign U.S. \$85.00. Single copy \$12.00. Buyers Guide \$40.00 CDN plus taxes.

Postal Information:
Printed in Canada. Publications Mail Agreement PM # 41515012
Return undeliverable Canadian addresses to CFCM Magazine Return undeliverable Canadian addresses to CFCM Magazine, Suite 259, 2186 Mountain Grove Ave. Burlington, ON Canada, L7P 4X4, Copyright 2021.

Contents of this publication may not be reproduced either in part or in full without the written permission of the publisher. CFCM makes every effort to report product news supplied by manufacturers accurately, however it is not responsible for the validity of any claims.

Wilkinson Media Inc.

Suite 259
2186 Mountain Grove Ave.
Burlington, ON Canada
L7P 4X4

INDUSTRIAL FINISHING

26 Aerospace Coatings

34 UV Curing Systems

37 Manual Liquid Paint Spray Guns

40 Powder Coating Spray Equipment

**PLATING AND ANODIZING**

52 Air Pollution Control Equipment

55 Thermal Control

57 Stack Testing

**PAINT AND COATINGS MANUFACTURING**

43 Antimicrobial and Antiviral Coatings

46 Testing Equipment

49 Biocides Manifesto, by Gary LeRoux

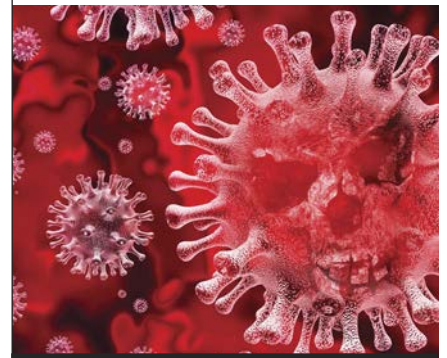
**DEPARTMENTS**

6 From the Editor

7 In the News

16 Calendar of Industry Events

18 CPCA Corner

22 CASF News

67 New Products and Technologies

70 Ad Index



On the Cover:
Aerospace coatings take off.
Image: Shutterstock

Fresh Start

Welcome to 2021 and to the new-look CFCM!

What a great time for a fresh start! In our efforts to make the magazine fresh, clean and modern, we've gone cover to cover, examining every design element. You'll notice we've changed up the font and headlines, the colors and just about every detail in some way. We think it's brighter, more airy and more fun!

We've also added a new editorial focus every issue on major application areas such as marine, architectural and automotive coatings. This issue we look at how coatings in the aerospace industry have really taken off.

According to the Aerospace Industries Association of Canada and Innovation, Science and Economic Development Canada, the aerospace industry valuation in 2018 stood at an impressive US \$31 billion and meant more than 213,000 jobs in the Canadian economy.

Though we seem to be more connected than ever – more wired – the pandemic has left us feeling more disconnected than ever. We crave the normalcy, familiarity and human-to-human contact that has been stripped away.

We know that our magazine and website are where you come together to connect with us and with experts and associates in the industry. That remains constant. It is our mission to continue to foster these connections and help drive the industry forward. As advertisers and readers, we hope you are proud to have us on your desk.

It's my personal mission this year to make more powerful, meaningful connections in all aspects of life.

To that end, I'd like to hear what you think of our new look and anything else on your mind. Email me any time at theresa.rogers@cfcfm.ca with thoughts or ideas. I'd love to connect.



THERESA ROGERS
theresa.rogers@cfcfm.ca

**MAKE SURE YOU CHECK OUT OUR
BRAND NEW WEBSITE, TOO!**
WWW.CFCM.CA

Coming up in the **MARCH/APRIL ISSUE OF CFCM**

***Bonus Show Distribution**

Canada Woodworking East 2021
Saint-Hyacinthe, QC – April 8-9
www.canadawoodworkingeast.ca

Powder Coating 2021
Orlando, FL – April 27-30
www.conference.powdercoating.org

INDUSTRIAL FINISHING

- Large Structures
- Automatic Liquid Paint Spray Guns
- UV-Cured Wood Finishes

PAINT AND COATINGS MANUFACTURING

- UV Photoinitiators
- Mixing and Dispersion Equipment
- Plastics Recycling: How it Could Hurt Paint Production

PLATING AND ANODIZING

- Essential Components for Plating
- Plating Thickness Testing
- National Pollutant Release Inventory Reporting

SPACE CLOSING: FEBRUARY 9 • AD MATERIAL: FEBRUARY 16



Associate Publisher & Sales: Gillian Thomas
• 1-416-277-1269 • gillian.thomas@cfcfm.ca

Editor: Theresa Rogers
• 1-416-201-1975 • theresa.rogers@cfcfm.ca

www.cfcfm.ca



Hempel Sets New Strategy

Hempel Group A/S says it is embarking on an ambitious new strategy to double revenue as well as double its positive impact.

The company says 2020 was a year of transition. While still securing paint and coatings supply globally in a challenging COVID-19 year and developing core business areas, a new strategy on how to focus the 105-year-old company has taken shape. Within the next five years, Hempel says it will double revenue through refocused geographical priorities, focused segment leadership positions and M&A, while at the same time accelerating on sustainability, innovation and digitalization, according to Group President & CEO, Lars Petersson.

“When the world closed down in 2020 and global operations including ours were challenged, we sped up our strategy process,” he says. “Now we have laid the foundation for not only doubling our revenue but also for significantly increasing our positive impact for our customers, partners and employees. We will build leadership positions and invest in our core segments and put sustainability at the heart of how we do business.”

The strategy will be realized through both acquisitions and organic growth as well as investments in sustainability, innovation and digitalization. Hempel expects 50 per cent of revenue growth to come from M&A but the strategy also has a clear-cut emphasis on building market leadership positions in specific areas of our four chosen segments: Decorative, Marine, Infrastructure and Energy.

[NP]“By 2025, we expect more than 50 per cent of our revenue to come from sub segments and geographies where we have a leading position, compared to less than 10 per cent today,” Hempel says.

The new strategy sets goals for sustainability such as being carbon neutral in the company’s own operations by 2025 and also reducing the carbon footprint of its customers. To ensure a rigorous, scientific and well-documented approach to becoming a sustainability leader within the coatings industry, Hempel says it has committed to science-based targets. The sustainability framework will be launched in February 2021.

“Putting sustainability at the heart of how we do business will drive change both within Hempel and across our value chain through our products and services,” Petersson adds. “We see sustainability as a key enabler for growth, by helping our costumers reaching their sustainability targets. Our target to double in size in the next five years makes our commitment to sustainability even more important, and we are ready to make some bold decisions as we accelerate.”

www.hempel.com



PPG to Acquire Coatings Manufacturer Wörwag

PPG has reached a definitive agreement to acquire Wörwag, a global manufacturer of coatings for industrial and automotive applications. The transaction is expected to close in the first half of 2021, subject to customary closing conditions.

“Wörwag’s industry expertise in powder and liquid coatings for industrial and automotive applications is highly complementary to PPG’s business, and will help to further expand our product offering,” says Rebecca Liebert, PPG Executive Vice President. “The addition of Wörwag will also enhance PPG’s waterborne, direct-to-metal, liquid and powder coatings offerings, and allow us to further expand current customer distribution in key geographies.”

Wörwag, headquartered in Stuttgart, Germany, specializes in developing sustainable liquid, powder and film coatings. It operates locations in Germany, the U.S., China, South Africa, Mexico, Spain, Switzerland and Poland.

www.ppg.com

elcometer®'s
 CANADIAN HOME 🍁

TESTCOATINGS.CA





COATINGS INSPECTION



ADHESION TESTING



SURFACE VERIFICATION

✓ FREE SHIPPING ACROSS CANADA!

POWERED BY
 GENEQ inc.

SCIENTIFIC INSTRUMENTS SINCE 1972
Authorized Elcometer distributor in Canada

The Complete Finisher's Handbook 5th Edition Now Available

The Powder Coating Institute has released the newest edition of its Powder Coating: The Complete Finisher's Handbook.

The association says the 485-page handbook is a comprehensive guide for everyone performing powder coating operations and for those interested in learning more about powder coating technology.

"The fifth edition of the powder coating handbook is a complete update to every chapter covering the latest trends and technologies," says PCI's Education Committee Chairman Greg Dawson. "This edition features color photos and graphics that truly bring the concepts to life. PCI has a vast pool of members that worked incredibly hard to produce the latest edition in what is recognized as the authoritative resource manual on powder coating."

The book's 21 chapters are assembled in the order that the powder coating system operates. Topics include powder coating materials, production analysis, surface preparation, application methods and equipment, powder recovery, curing, maintenance, quality testing, troubleshooting, and more. The handbook also contains appendices with PCI technical briefs and recommended test procedures along with a system troubleshooting guide and a maintenance checklist. The book guides the reader in specifying and selecting equipment and powder materials that best meet end-user needs and provides assistance in all aspects of the powder coating process.

www.powdercoating.org/store

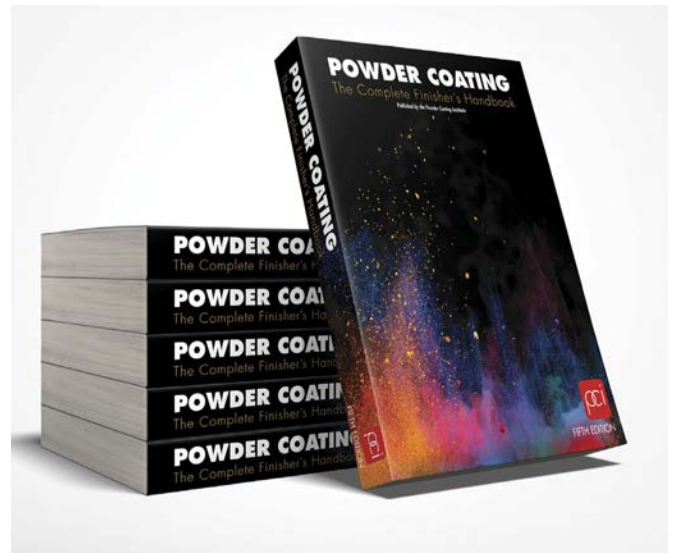

Topics include powder coating materials, production analysis, surface preparation, application methods and equipment, powder recovery, curing, maintenance, quality testing, troubleshooting, and more.

Axalta's 2021 Global Automotive Color of the Year: "ElectroLight"

Axalta has announced its 2021 Global Automotive Color of the Year is called ElectroLight.

The company says, "ElectroLight is an expressively refreshing green-yellow hue with inspired bold, contemporary flavors that echo style, energy and flair. The unique personality of ElectroLight evokes a blend of sporty design elements with functional performance and offers great versatility when combined with two-tone charcoal color accents or matte finishes on a variety of mobility solutions."

Axalta adds, ElectroLight is formulated with reflective properties that make it highly visible to light detection and ranging (LiDAR) systems, while its layer structure and pigment content are easily transmissible by radio detection and ranging (radar) systems.

"ElectroLight is another step toward illuminating a path for a green future for all type of vehicles, including autonomous vehicles," says Hadi Awada, a senior vice president at Axalta. "Formulated with mobility-sensing technology, ElectroLight combines a passion for individualization with coating science into a functional, expressive and dynamic color."

ElectroLight meets industry safety standards and improves the performance of both types of systems, making it a "stand-out color option" in both trend and technology.

While Axalta's 2020 Global Automotive Color Popularity Report shows that white remains the most frequently purchased automotive color globally, interest in automotive colors with a more customized and personalized look are becoming increasingly desired by consumers, the company says.

"Consumers are looking for a breakout color and ElectroLight manifests this, while bringing a progressive approach to automotive styling and design," says Nancy Lockhart, Global Product Manager of Color at Axalta.

www.axalta.com/color



EverCare Launches Tenray, a New Brand of Ultrafine Zinc Oxides for Industrial Applications

EverCare, a producer of ultrafine zinc oxides used in personal care and industrial applications, recently launched Tenray, a new brand focused on industrial application areas.

"As personal care applications are quite different from the industrial applications in terms of product and performance requirements, we decided to introduce Tenray to cover a new range of products focused on plastics, coatings and textiles," says Jeroen van den Bosch, EverCare's Managing Director. "The launch of Tenray will allow us to apply a dedicated focus on the specific needs of plastics, coatings and textiles applications."

The Tenray portfolio will include coated and uncoated ultrafine zinc oxides, food and non-food approved grades, with new products and product forms being added in the near future.

www.everzinc.com

Erie Powder Coatings (EPC) has been offering custom and stock powder coatings and manufacturing powder coatings in Niagara since 1994. Erie has built up a strong customer base on both sides of the border and across North America. The company is very flexible, able to manufacture products from 10,000 kg or more down to a single box. The addition of a U.S. facility near Erie, PA, has added a great advantage for Erie's customers, many of which also have operations on both sides of the border, to purchase from both facilities.

The addition 10 years ago of the U.S. facility has allowed the company great flexibility in dealing with customers. While the Canadian facility acts as a manufacturing base and corporate headquarters, the U.S. facility allows local production of coatings to the U.S. market, as well as warehousing and sales functions.

Erie offers a strong line of custom manufactured products, built to customers' specifications. The company offers a unique ability to offer small volume custom-built orders, while still being competitive on larger volumes, and also offering advanced chemistries and coatings.

EPC has had a strong offering in some very specialized markets, such as anti-corrosion coatings, anti-graffiti coatings, and SEFA (Scientific Equipment and Furniture Association) grade coatings.

EPC found that the standard zinc rich corrosion primers on the market had a big problem in application – real problems with inter-coat adhesion which can lead to disaster for users of this type of product. Erie has fixed this problem and made this type of powder far easier to use successfully. Erie is currently marketing two zinc primers for this type of application.

Several anti-graffiti (AG) chemistries are available, but the newest and most popular product is the hybrid anti-graffiti product. This product

is substantially different from others on the market. Other AG products are expensive, difficult and often contain a number of hazardous ingredients. Erie's hybrid AG products have the distinct advantage of being fast cure but oven stable, and free of TGIC and isocyanate, which are often used in these products.

SEFA sets standards for laboratory furniture and cabinets. Erie has been active in this market and has qualified powders that meet or exceed these specifications. While this is a select

and niche market, Erie has found this market to be a strong one.

Fast cure product lines are also a specialty that Erie excels in. One of the primary reasons for this is the type of equipment that Erie uses – specialty Swiss-made plastics extruders that are better at producing low-cure temperature coatings than other types of extruders.

Erie Powder Coatings is proud to be ISO 9001:2015 compliant.

ERIE Powder Coatings



not just black & white...

For a colour brochure call us: 905-957-4086

NEW DATES!

**POWDER
COATING
WEEK
2021**



PRESENTED BY  Powder Coating Institute

POWDER COATING 101

Powder Coating Done Right: The Basics



**Powder Coating
Technical Conference**



April 27-30, 2021

Renaissance Orlando
at SeaWorld®

conference.powdercoating.org

**PPG to Acquire Global Coatings
Manufacturer Ennis-Flint**



PPG has reached a definitive agreement to acquire Ennis-Flint, a global manufacturer of coatings with a portfolio of pavement marking products, including paint, thermoplastics and other traffic technologies. The transaction, valued at approximately US\$1.15 billion, is expected to close within the next few months.

“The acquisition of Ennis-Flint will further expand our product offering and opportunities in rapidly developing and high-growth mobility technology solutions,” says Michael McGarry, PPG Chairman and CEO. “The company is well known for its high-quality products, technical expertise and innovative systems. The addition of Ennis-Flint’s products further enhances our existing mobility technologies in support of increased automotive occupant safety through driver-assisted and autonomous driving systems. We look forward to the Ennis-Flint team joining PPG and working together to further expand the company’s product distribution on a global scale.”

PPG says it formed a mobility focus team in 2017 to develop mobility technologies and innovative technical solutions that provide increased functionality and solve new and unique requirements for electric, hybrid and autonomous vehicles. Mobility-related products developed by PPG include battery-specific coatings for safety and performance, autonomous vehicle coatings for vehicle and infrastructure visibility, and interior coatings for surface functionality and durability.

Ennis-Flint supplies a wide range of products including traffic paint, hot-applied and preformed thermoplastics, raised pavement markers and intelligent transportation systems.

“We are excited to join the global PPG family,” says Matt Soule, President and CEO of Ennis-Flint. “Our products and technologies are excellent complements to PPG’s current product offering, and the ability to leverage PPG’s world-class innovation and broad geographical footprint will provide more growth opportunities for our products and employees in the future.”

PPG will provide additional details relating to the business acquisition, including acquisition-related financial impacts, during the company’s fourth quarter earnings conference call in January 2021.

www.ppg.com

The acquisition of Ennis-Flint will further expand our product offering and opportunities in rapidly developing and high-growth mobility technology solutions.

New Organization for Corrosion and Protective Coatings Industries Unveiled



To create a unified voice for the corrosion control and protective coatings industries, a new association launched January 6, at a global virtual event.

The new organization, the Association for Materials Protection and Performance

(AMPP), was formed by a merger between Houston-based NACE International, The Corrosion Society; and Pittsburgh-based SSPC: The Society for Protective Coatings. AMPP's name, logo, and other brand elements were revealed at the event led by AMPP CEO, Bob Chalker and the organization's executive leadership.

"AMPP brings together the world's leading corrosion prevention and protective coatings organizations under one umbrella," says Chalker. "With a vision to create a safer, protected, and sustainable world, the new association will focus on the future of materials protection and performance."

With more than 40,000 members in 130 countries, AMPP consists of two governance structures— AMPP and AMPP Global Center. AMPP provides services to members in the areas of certification, accreditation, membership, advocacy and public affairs, while AMPP Global Center focuses on standards, technical and research activities, conferences, events, education, training, publications, and preprofessional programming.

While the AMPP staff has been working together seamlessly since October, some program details such as accreditation and certification continue to evolve. For the near future, NACE and SSPC accreditations and certifications will remain as they are currently.

"For years, AMPP's new combined membership has been aligned in one very important way: our members are dedicated to protecting infrastructure and assets from corrosion and deterioration," says Chalker. "Guided by this common purpose we will be a stronger, more powerful voice for our industry by working together."

www.ampp.org



Venjakob Group Starts New Year with New North American Brand Strategy

Venjakob Group says for strategic reasons and to further sales and services, it is repositioning its branding. Nutro Inc., a member of Venjakob Group which supplies automated finishing systems, will adopt the corporate design of the Venjakob Group. Venjakob North America Inc. will also follow suit.

For the customers and business partners of both Venjakob North America and Nutro, nothing will change.

The company says customers and business partners will benefit from a strong team. Contacts will remain the same and it is business as usual.

Venjakob, headquartered in Rheda-Wiedenbrueck, Germany, was founded in 1963 and is currently under third-generation management.

The company says it and Strongsville, OH-headquartered Nutro complement each other by

offering tailored turnkey coating systems. If the in-house technical center in OH does not have the desired test system, it may be available in Germany.

Venjakob adds that the power of the group's component companies, all expert in the field of surface technology, offers the prospect of a successful combined future.

www.venjakob.de/en



PosiTest[®] DFT

NEW

Coating Thickness Gages

2 models

- Ferrous for Steel**
- Combo for All Metals**

- Fast, repeatable measurements (60+ readings per minute)
- Ready to measure—no adjustment required for most applications
- Onscreen averaging for up to 99 readings
- Strong, wear-resistant, ruby-tipped probe
- Two year warranty on gage body AND probe

www.defelsko.com

1-800-448-3835

simply
measures

DeFelsko[®]

The Measure of Quality

DeFelsko Corporation • Ogdensburg, New York USA

Tel: +1-315-393-4450 • Email: techsale@defelsko.com

People



Susan Bailey

Radtech Elects New President, Board

RadTech has announced the election of Susan Bailey, from Michelman, as President. Michael Gould, Rahn USA is nominated as President Elect to assume office in 2023. In addition, new members elected to serve a two year term include: Neil Cramer, Sartomer; Jonathan Graunke, INX Intl.; Jennifer Heathcote, GEW; Helen Rallis, Sun Chemical; Jake Staples, Wausau Coated Products, Inc. and Dan Theiss, Procter & Gamble.

“The UV+EB community represents a growing number of important technology applications, and we welcome our new Board members to help develop these opportunities,” says Bailey. “Our focus now is working to deliver much needed goods and supplies, including fast custom labeling, printing and packaging; supporting medical suppliers; and offering additive and electronics manufacturers with unique materials. This work requires targeted networking and the sharing of technical and training information that RadTech helps provide.”

RadTech thanked Board members who will be rotating off at the end of this year after fulfilling a two-term limit: David Biro, Sun Chemical; Mike Bonner, Saint Clair Systems; Christopher Seubert, Ford Motor Com.; Hui Yang, Procter & Gamble; and Sunny Ye, Facebook. In addition, Eileen Weber of allnex moves to the position of immediate past president.

www.radtech.org

Dynamix Welcomes New Lab Tech



Paola Yustres

Dynamix has appointed Paola Yustres as a lab technician. She holds a Chemical Laboratory Technologist diploma from Seneca College.

“Paola’s customer dedication, laboratory skills, and experience are a welcomed addition to our industry-leading laboratory,” says Michael Black, Marketing Manager.

www.dynamix-inc.com

Trinseo Welcomes New Technical Sales Representative to CASE Team

Trinseo has announced the appointment of Joseph Clarke as technical sales representative supporting its CASE (Coatings, Adhesives, Sealants, and Elastomers) business.

Trinseo says it has recently allocated additional time and resources to CASE, expanding the team and capitalizing on its growth. Deemed a transformational period in Trinseo’s history by leadership, now is an exciting time for Clarke to join CASE and contribute to its success, the company adds.

Clarke most recently served as the lead sales representative at Honeywell UOP in Des Plaines, IL, where he developed technology for odor control in packaging and plastics applications, and moisture scavenging in paints and coatings markets.

With more than 25 years of experience in the chemicals industry, Clarke special-

izes in developing new business, managing distribution networks, and executing regional sales strategies. He holds a bachelor’s degree in biological science from Southern Illinois University, Carbondale.

Clarke will be responsible for growing Trinseo’s CASE portfolio and developing new business with new applications, new markets and alternative chemistries.

www.trinseo.com



Joseph Clarke

De Nora Tech is a global leader in the development, manufacturing and sales of mixed metal oxide anodes for electrochemical plating processes. De Nora Tech (DNT) provides support to its customers by providing high-level, on-time electrode delivery, ISO 9001-2015 product consistency, and proven superior plating performance. DNT supports customers' commercial needs by delivering specialized technical product assistance.

Whether your plating needs are considered standard geometric structures or cutting-edge intricate prototypes, De Nora Tech has the resources and knowledge to promote your success. Proven science coupled with precise application protocol ensures quality surface plating cycle after cycle. DNT has you covered with one-stop supply of custom designed MMO Auxiliary anodes, Primary MMO anodes for Tri-chrome, MMO Balancing anodes, and Platinum plated Ti/Nb anodes.

De Nora Tech demonstrates proven experience, excellence, and reliability across its diverse electrochemical product line. De Nora's Dimensionally Stable Anodes (DSA®) technology is widely used in chemical, metal electrowinning, electrolysis, water treatment, cathodic protection, and other industries.

Through its state-of-the-art Technology Center located in Concord, OH, and electrode manufacturing/ coating facility located in nearby Mentor, OH, De Nora Tech remains well positioned to service its North American clients. Building on the legacy of ELTECH Systems (acquired in 2005) De Nora Tech recently completed a state-of-the-art 130,000-sq. ft. manufacturing facility in nearby Mentor, OH. The \$31-million investment is in operation and a further expansion in support of additional business is already in planning. Currently, DNT has established coating capacity to 1.7 million sq. ft. annually.

De Nora Tech is part of the worldwide De Nora Network operating 12 manufacturing facilities across the globe with De Nora's corporate headquarters located in Milan, Italy. With more than 95 years in business, De Nora aims to strengthen its position as the world's leading provider of electrochemical products and services by uniting a unique value proposition of economic success, respect for the environment, and social responsibility.

De Nora Tech, LLC

7590 Discovery Lane, Concord, OH 44077
dntinfo@denora.com

Timothy Tan, Senior Account Manager
T. (440) 478-7279
timothy.tan@denora.com

Carl Brown Jr., Technical Assistance Manager
T. (440) 487-8731
carl.brown@denora.com

DRIVING...

innovation development operations success

DE NORA Tech product offering includes:

- Custom MMO Auxiliary anodes
- Primary MMO anodes for Tri-chrome
- Anode plates for EGL/ETL
- Platinum plated Ti/Nb anodes
- Customizable tube anodes for E-Coat

Beyond the Surface

DNT expertise at:
surfacefinishing@denora.com

Connect!!

De Nora Tech, LLC
Concord, OH
440.710.5300
Denoratech.com

ISO 9001:2008

CALENDAR OF EVENTS

April 8-9, 2021

*Canada Woodworking East
Espace Saint-Hyacinthe
Saint-Hyacinthe, QC*
www.canadawoodworkingeast.ca

April 27-30, 2021

*Powder Coating Week
Orlando, FL*
www.conference.powdercoating.org

April 28-30, 2021

*Women in Finishing Forum
Embassy Suites South Bend at Notre
Dame, South Bend, IN*
www.ccaiweb.com/page/WiF

May 26-27, 2021

*Canadian Paint and Coatings
Association Annual Conference
Quebec City, QC*
www.canpaint.com

July 13-15, 2021

*SUR/FIN
Detroit, MI*
www.nasfsurfin.com

September 13-16, 2021

*Fabtech 2021
McCormick Place, Chicago, IL*
www.fabtech-chicago-exhibition.com

September 21, 2021

*CASF Golf Tournament
Whistle Bear, Cambridge, ON*
www.casf.ca

September 28-30, 2021

*ABRAFATI 2021
Sao Paulo, Brazil*
www.abrafatishow.com.br

November 4-6, 2021

*Woodworking Machinery Supply and Expo
Mississauga, ON*
www.woodworkingnetwork.com/event/s/woodworking-machinery-supply-conference-and-expo

April 5-7, 2022

*American Coatings Show
Indianapolis, IN*
www.american-coatings-show.com

April 26-29, 2022

*PaintExpo
Karlruhe, Germany*
www.paintexpo.com

June 2022

*Fabtech Canada
Toronto, ON*
www.canada.fabtechexpo.com

IGM Resins Appoints New CEO

IGM Resins has appointed Wilfrid Gambade as CEO, effective January 1. Gambade, based in IGM's headquarters in Waalwijk, the Netherlands, succeeds Edward Frindt as CEO. Frindt joined the company in 2012 and will retire from IGM at the end of Q1.

"On behalf of the Board of Directors, I would like to thank Edward for his significant contributions to IGM for the last nine years," says John Huiberts, Founder of IGM Resins and Chairman of the Board. "I wish him a happy retirement and appreciate his support working alongside Wilfrid to ensure a smooth transition of leadership. Wilfrid is a proven and experienced strategic leader with deep understanding of the chemical industry. He brings with him a track record of strategic positioning and strong executive leadership experience which will be integral as we continue to further build sustainable business growth for IGM Resins. I am excited to welcome a seasoned industry executive to lead the IGM team toward continued future success."

Gambade has 25 years of international management experience in the chemical industry. He joins IGM from DSM where he served as President of Composite Resins from 2011 to 2014, as President of Personal Care & Aroma from 2014 to 2018, and as President of DSM Dynema (DSM Protective materials) since 2018.

www.igmresins.com

Gambade is a proven and experienced strategic leader with deep understanding of the chemical industry.



Wilfrid Gambade

Graham Douglas Assumes Role of President at CASF

The Canadian Association for Surface Finishing, through its Board of Directors, announced Graham Douglas has assumed the position of President of CASF for a two-year term.

Bob Smith, outgoing President, welcomed Douglas to his new position during the association's board meeting in November. Douglas is well known in the industry, having spent the past 30 years supplying surface finishers. He is currently Sales Director for UBA Ontario and Kencro Chemicals based in Oakville, ON. A CASF board member since 2018, Smith says Douglas has already brought many exciting ideas to the board which looks forward to his high-energy approach in the coming months.

www.casf.ca



Graham Douglas



Daemar manages the sourcing and delivery of millions of essential components including the complete line of Caplugs masking and protective products to Canadian manufacturing and finishing industries. Our Caplugs inventory includes more than 12,000 lines of standard parts – featuring caps and plugs developed specifically for masking applications and available in materials including: silicone, EPDM, Flex 500 and vinyl. Our tapes and standard die-cut discs are available in polyester, polyimide, glasscloth, crepe, aluminum and more.

Do you require a unique shape, size, color, material or processing requirement? Daemar’s technical team along with Caplugs’ in-house design engineers can develop

custom moulded parts, custom die-cuts and custom kits for specific applications.

For more than 40 years, Daemar has provided solutions for industry applications from high volume production lines requiring design assistance and supply chain management, down to a simple one-off application requiring a single cap. Daemar’s regional warehouse network with stocking facilities in Toronto, Montreal and Edmonton provides fast and efficient delivery of parts to customers throughout the country.

Trust Daemar and our extended team’s expertise to solve your masking challenges.



Masking and Part Protection Solutions for Industrial Finishing Processes

www.daemar.com

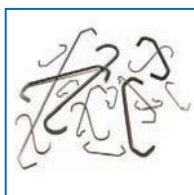

Essential Components for Industry

CAPS & PLUGS

- Silicone Rubber
- EPDM
- Flex 500 Vinyl
- Green & Black Neoprene
- Thousands of standard designs

TAPES & DISCS

- High temperature applications
- Polyester tapes
- Polyimide tapes
- Glasscloth, Paper & Silicone Rubber
- Standard die cuts in discs, squares and more

CUSTOM MASKING

- Prototype tooling
- Custom moulded masking
- Custom die cut masking
- Custom hanging solutions

Oakville, ON
905.847.6500

Dorval, QC
514.636.3113

Edmonton, AB
780.435.8899

Atlanta, GA
770.953.4710

1.800.387.7115

DON'T MISS ANOTHER ISSUE OF CFCM

- FREE SUBSCRIPTION FOR QUALIFIED CANADIAN READERS - PRINT, DIGITAL OR BOTH!
- FREE DIGITAL SUBSCRIPTION FOR U.S. READERS

Subscribe today at
www.cfcmm.ca



Left: CO2 snow blast cleaning device offers parts cleaning suitable for all industries.

THE PRETREATMENT PROCESS is designed to prepare a product's surface for painting, plating or other types of industrial finishing, and is probably one of the most important processes on the way to a finished product. If a plant is applying paint or powder, it allows for the proper adhesion of the coating to the substrate and sets up the long-term success and durability – or not – of that coating.

The surface cleaning process removes unwanted layers or particles from component surfaces. This can be done in a variety of ways such as CO2 blasting, dust removal/ionization, water-based cleaning, or degreasing.

MECHANICS
Venjakob's CO2 blasting machines can be used as a standalone solution or installed upstream into existing processes. The company recommends this process for guaranteed residue-free cleaning of components and thus flawless coating.

CO2 blasting can be done by snow blasting or using dry ice on small 3D parts to large workpieces in large batches.

With snow blasting, a cold burner produces its own dry ice from liquid CO2. The cleaning blast consists of a mixture of CO2 snow particles, CO2 gas that's not converted into particles and compressed air.

Dry ice cleaning works in a way that's comparable to abrasive blasting or hydroblasting. Solid CO2 pellets (solid carbon dioxide, often referred to as "dry ice pellets") are used rather than water, sand or other abrasive materials. Made from a mixture of compressed air and dry ice particles, the cleaning jet hits the surface to be cleaned at high speed. It is suited for metal, plastics, glass, ceramic, and building materials.

TX offers all sorts of multi-stage pretreatment equipment. Using spray, immersion or a combination of pretreatment methods, dirt, oils and contaminants are removed from the product's surface and phosphate or conversion coatings are applied to help prevent corrosion and increase paint adhesion, the company says.

Systems can be customized to suit any electrocoating, powder coating, liquid spray-painting, cleaning, pretreatment, or heat-treating operation.

Pretreatment systems are PLC-controlled, have automatic startup and shut down programs and are designed with computer-aided rise ratios allowing reduced water usage and in some cases, a zero discharge system, TX says.

Once a workpiece is clean, it will likely undergo a surface activation process.

Many materials don't have the necessary surface tension for further processing such as bonding and coating, Venjakob says. Potential reasons include surface imperfections resulting from flaws or pores or possibly the chemical composition of the substrate, which may result in substance or processing aid diffusion on the component

surface, surfaces, the comp, nonporous surfaces, for impro, The co, plasma or. With bl, treated w, surface ter, flame treat, gas flame, This bl, treated st, groups cal, way, polid, material th, coatings, developm, of the tra

CHEMIST
PPC offer, metal safe, zinc, and, film treat, the comp, The PP, efficient z, corrosion, manufact, reduced st

Operating principles of CO2 blasting technology.
www.cfcmm.ca CANADIAN FINISHING & COATINGS MANUFACTURING 21



Advertising Contact: Gillian Thomas • 1-416-277-1269 • gillian.thomas@cfcmm.ca

www.cfcmm.ca

Beyond Chemistry

More than words, this motto represents EMCO-Inortech's "raison d'être", always striving to give unique and unparalleled service to our customers and suppliers.

The great experience of EMCO-Inortech's personnel at the customer service, sales, regulatory and technical levels will, without a doubt, enable you to successfully establish new technologies. Our laboratory is always maintained at the cutting-edge of technology and we constantly make sure that the latest equipment is available. In doing so, we ensure outstanding support to our customers and suppliers.

EMCO-Inortech's mission is always to push to the limit of the technologies offered by our suppliers and others for innovative and leading-edge solutions.

In order to maintain our technology expertise and the excellent interpersonal skills so well recognized by the market we serve, all EMCO-Inortech's personnel, without exception, are encouraged to go to conferences and seminars, and to follow continuous professional development.

For the last 30 years, EMCO-Inortech has strived to help customers successfully secure new opportunities, supported by its unparalleled technical team. Also, for our suppliers, we assure outstanding visibility and excellent market penetration.

Being proactive in the markets we serve – coatings, inks, plastics and adhesives – and being especially attentive to our customers' demands and problems, we always make sure that the selected supplier is at the cutting edge of their technology. This approach strengthens and guarantees a long and fruitful partnership with our customers and suppliers.

In this day and age, delivery on short notice and on time is a paramount asset for our customers and suppliers. Our Canadian public warehousing network helps us to make sure that our customers have the material when needed and on time.

EMCO-Inortech's success has always been its outstanding capacity to understand new technologies and to be able to explain them to our customers. This forces EMCO-

Inortech's staff to always adapt, and be on top of the ever-changing market conditions.

Because of its unique and "avant-garde" business model, EMCO-Inortech can be part of your team and pivotal to your success.

Together, we can succeed...

Head Office

3014 rue Anderson
Terrebonne, QC, J6Y 1W1
Customer service: 1-800-661-2064
www.emcochem.ca

*EMCO Chemical Distributors Canada Ltd.
and Inortech Chimie Inc. are now*

EMCO[®]

INORTECH

EMCO CHEMICAL
DISTRIBUTORS
CANADA LTD.

INORTECH
CHIMIE INC.



*The synergies of EMCO Chemical Distributors
Canada and Inortech generate a full line specialty distributor
and a leader in the CASE, Ink and Plastic industries.*



CANADIAN PAINT
AND COATINGS
ASSOCIATION

ASSOCIATION CANADIENNE
DE L'INDUSTRIE DE LA PEINTURE
ET DU REVÊTEMENT



3014 Rue Anderson

Terrebonne, QC J6Y 1W1

Phone: (450) 621-1999 • 1-800-661-2064

www.emcochem.ca

CURRENT PAINT AND COATINGS ISSUES IN CANADA

By Gary Leroux

Federal Ban on Critical Paint Preservative Reversed

CPCA was pleased to announce that the Canadian government's Pest Management Regulatory Agency reinstated the use of OIT for paint and coatings and related products in Canada. The substance had been prohibited for use in these products since May 2019 and the ban had been a sticking point in discussions around the lack of alignment between Canada and the United States on re-evaluation of antimicrobial preservatives.

The decision to reverse the ban will ensure that paint producers have access to a critical ingredient used for the preservation of paint and stains, which has been integral to the transition from solvent to water-based coatings over the past decade. In addition, the same data used to re-evaluate OIT led to more positive news for industry when the usage rates for another important preservative – CMIT/MIT – reverted to previous functional values in Canada and into full alignment with the United States.

This points to the dire need for officials re-evaluating critical substances to fully consider all the available science-based data in rendering final decisions. Currently, Canada is re-evaluating six other critical biocides used in coatings and adhesives/sealants and a robust submission was made by CPCA and its members to ensure proper values are used in risk calculations at every level.

CPCA Submits Major Comments on Re-evaluation of Six Critical Paint Biocides

In December, CPCA finalized a major submission to the Pest Management Regulatory Agency on the ongoing re-evaluation of six paint biocides used for antimicrobial control, which are critical for the coatings industry in Canada, namely, chlorothalonil, ziram, folpet, dazomet, diodofon, and sodium pyrithione. Supplier and manufacturer members provided critical data to inform industry's position reiterating the need for holistic re-evaluations of paint preservatives using risk calculations that are reasonable in terms of toxicity related to risk calculations.

In the past we have seen values that far exceed those of the US EPA for the same ingredient, which causes severe problems for both product formulations as well as trade and commerce between the largest trading partners on the globe. These issues prompted CPCA to work with PMRA on the creation of a Coatings and Adhesives Working Group for a more robust collaboration and a realistic framework for both PMRA and industry, one that is based on science first and foremost. This work is critical for the paint indus-

try in Canada as these preservatives are part of a very limited array of biocides still registered for use in the coatings industry.

New VOC Limits Coming in 2021

The latest biannual meeting of the sectoral Paint and Coatings Working Group took place on December 3, 2020. Regulatory officials from Health Canada and Environment & Climate Change Canada provided updates on multiple sector issues. Members were informed that government is now aiming for the adoption of CARB 2019 VOC limits in the proposed amendment to the Architectural VOC regs next year. Ten other industrial categories, not covered under current regulations, may be added as part of this effort. Members were informed that government seems to be aiming for the adoption of CARB 2019 VOC limits in a proposed amendment for 54 categories in the Architectural VOC regulations beginning in 2021.

A more formal consultation will take place in the Spring of 2021, while CPCA continues advocating for the adoption of OTC Phase II limits over CARB, but that may be a difficult road ahead. CPCA consultations with member companies will resume early in 2021.

Declaring Plastics Toxic

There are a number of upcoming publications for chemical assessments for the coatings sector, several re-evaluations for key biocides used in coatings, and the recently announced plastic waste initiative proposes to add 'manufactured plastic products' to Schedule 1 of the Canadian Environmental Protection Act (CEPA), designating them as toxic. This would be an unfortunate precedent-setting case that would henceforth capture other manufactured products when the Act was in fact designed to conduct risk assessments on substances used in products, not the 'manufactured' product. This has been done under the Chemicals Management Plan for the past 15 years. It is unclear the federal government would make such a process work, if indeed it were to proceed.

If it does proceed, it would also capture polymer dispersions as microplastics would also be designated as toxic by CEPA, under Schedule 1 of the Act. If this amendment proceeds it could greatly impact polymer dispersions now used in a wide range of product formulations. CPCA and many other industry associations, both in Canada and the United States, have filed Notices of Objection of the Order proposing such an amendment.



CANADIAN PAINT
AND COATINGS
ASSOCIATION

ASSOCIATION CANADIENNE
DE L'INDUSTRIE DE LA PEINTURE
ET DU REVÊTEMENT

HELPING YOU COVER THE WORLD

CPCA supports an industry with an economic impact of \$12.2 million annually creating 87,000 direct and indirect jobs for Canadians. The paint and coatings industry is rooted in evidence-based science, which is the foundational building block for safe, sustainable and highly performing products. Membership includes leading manufacturers and their suppliers, distributors and affiliated companies.

Companies choose CPCA time and time again because of our results oriented advocacy that reduces regulatory burden, supports compliance and mitigates current and future risks for companies in Canada.

Innovative Association Management

CPCA's work focuses on managing issues that impact paint and coatings in all segments of the industry — Coatings, Adhesives, Sealants and Elastomers (CASE). Members are provided with real-time updates through CPCA's 'member only' online regulatory platform — Canada CoatingsHUB. The HUB includes a comprehensive database of over 1,500 CASE related resources, substances, and compliance alerts covering issues that matter:

Chemicals Management | Hazard Communications | Product Stewardship & Recycling
Innovation & Sustainability | Toxics Reduction | Air Quality Regulations | Environment, Health & Safety
Risk-based Chemical Assessment | Canada-US Regulatory Alignment

Guiding Principles

Excellence

Focused and experienced, harnessing the power of members for the best evidenced-based advocacy possible on the most critical issues to help sustain and grow business in Canada.

Innovation

CPCA is agile and continuously evolving to better serve our membership, providing timely information and trusted advocacy with governments and key stakeholders.

Persistence

CPCA pushes the boundaries on industry issues to illuminate often complex challenges; minimize potentially negative impacts of pending government policy and regulation; while at the same time ensuring full compliance for the best products available to Canadians.

Members are the backbone of CPCA as they provide the relevant data and insights driving our advocacy efforts for positive results for industry in Canada.

Help Us, Help You. Join CPCA!

canpaint.com



As the federal government moves forward with further chemical assessment of chemicals of concern, CPCA will continue to update the substance database for each chemical assessed under the CMP.

Ongoing Chemicals Assessment Activities

The ongoing risk assessment of chemicals in commerce continues under the Chemicals Management Plan, which has now resumed regular publications after delays due to the pandemic. CPCA continues to monitor the substances implicated in coatings, sealants, and adhesives and updates members on regulatory actions via our digital platform, the Canada CoatingsHUB, as well as regular bulletins.

CPCA was pleased that the final screening assessment for the Phenol-formaldehyde Resins Group concluded that all eight substances are not toxic under CEPA, since these are heavily used in paint and ink formulations. The final assessment for the Phthalates Group was also recently published. One of the 28 substances was proposed for prohibition in Canada while 20 others will be closely monitored with follow-up activities.

Additional details on the health risks associated with the Flame Retardants Group became available, which prompted the publication of updated draft assessments and risk management scopes for three substances in this group. These three – melamine, TCPP, and TDCPP – are now proposed as being toxic under CEPA and members were urged to review their uses in textile and furniture coatings in Canada. Finally, at the recent Paint and Coatings Working group meeting, government officials confirmed that the draft screening assessment for the Titanium group (which includes titanium dioxide, TiO₂) is delayed until July 2022 due to competing priorities.

There are several groups of CASE-implicated (coatings, adhesives, sealants, and elastomer) substances being assessed between now and the end of 2021. Some key publications will be delayed because of COVID-19. CPCA continues to monitor closely Final Screening Assessment Reports (FSAR) for benzophenone, which will likely be concluded toxic at a very low level, hence affecting some resins currently used for indoor and exterior consumer paint products.

Also expected is the publication of the Final Screening Assessment Reports (FSARs) for pigments and dyes and fatty acids, and their derivatives that are proposed non-toxic, as well as for triarylmethanes where there are two substances proposed toxic. Draft Screening Assessment Reports (DSARs) will be published for acid and bases and monitoring continues on the DSAR publications on naphthalene sulfonic acids and salts, alcohols, aliphatic amines. CPCA submitted comments on the DSAR for ketones, challenging the toxicity decision for MEK, MIBK, and 2,4-PD, which are used in certain liquid and aerosol paint and coatings products; and more widely, in allied products (thinners, removers) available to Canadian consumers. Similarly, also soon to be published will be the FSAR for the Furan group in which furfuryl alcohol is proposed as toxic for its current use in wood strippers with no cost-effective substitute available; as well as tetrahydrofuran, a common solvent in industrial CASE products, and comments were filed by CPCA on those substances.

The DSAR for ethers, manganese, aluminum and titanium compounds and titanium dioxide, are postponed no later than Winter 2021. CPCA will be watching out for other important DSAR publications in 2021, such as for benzotriazoles and benzothiazoles, esters, ethers, silver, and other polymers, for which the government did not provide any timeline in 2021. The government did not confirm the DSAR publication previously expected in Summer-Fall 2020 for piperazine and substituted phenols, neither for the FSARs for siloxanes (non-toxic), epoxides and glycidyl ethers (non-toxic) and petroleum coal tars and base oils (non-toxic), among others.

For NMP, CPCA learned that the final report is being delayed until a more final evaluation can be published by the US EPA under TSCA. The TSCA draft risk evaluation report was published at the end of last year, along with a risk management evaluation document, and a final risk evaluation report is expected at the end of 2020 or in the first part of 2021. For anthraquinones, the current levels of these non-toxic substances will continue to be tracked and may be the object of future actions by the government. Recent chemical assessment reports included Turpentine, Zinc Compounds, Resins and Rosins, Talc, Copper Compounds, and several others of interest to the coatings sector. Status, submissions and other reports for all of these are posted on the Canada CoatingsHUB.

Chemical Substances Database for Canada

To stay on top of the ongoing regulatory changes, CPCA added a chemical substance database to the CoatingsHUB last January. It contains more than 1,100 substances known to be used in the CASE sector, the status of which can be searched by CAS RN. These CASE-related substances were identified based on data obtained from CPCA members and from government information derived from various Section 71 mandatory information gathering initiatives under the CEPA since 2006.

As the federal government moves forward with further chemical assessment of chemicals of concern, CPCA will continue to update the substance database for each chemical assessed under the CMP. This ensures all information in the database is current and can easily be reviewed by members via the Canada CoatingsHUB. Moreover, it ensures a company can plan for any changes potentially impacting its products – whether bans, use restrictions or new uses – thereby ensuring full compliance for those products in Canada. No other sector and no other country has such a comprehensive chemical substance database specific to the coatings industry within a country, according to a globally recognized expert on both digital platforms and the coatings industry. ■

Gary LeRoux is President and CEO of the Canadian Paint and Coatings Association. www.canpaint.com

MOCAP is a leading manufacturer of standard and custom, plastic and rubber injection-molded, dip-molded and extruded products. We offer a full line of caps, plugs, grips and tapes for product protection, masking and finishing purposes, sold to virtually every industry for countless applications.

In business since 1982, MOCAP's philosophy has always focused on finding the right solution for our customers whether through our standard or custom products. We serve our customers' requirements globally, with locations in North America, Europe and China.

We currently offer a full line of masking products in various materials designed to meet the requirements of nearly any coating/finishing application. Materials range from one-time use high temperature vinyl to ultra high-temp reusable silicone rubber, while our extensive product line includes standard cap and plug configurations, as well as pull plugs, washer plugs, tapes, discs and tubing. The products can be used for your high temperature painting, plating, anodizing and coating operations, and in some cases, like EPDM and silicone products, can be used repeatedly for optimum savings.

Some of our Masking Products include:

High Temperature Vinyl Caps and Plugs – Designed for one-time use, our caps and plugs are available in various sizes and styles to meet your requirements. The high-temp vinyl will withstand approximately 450 F for 30 minutes.

EPDM Caps and Plugs – Designed for repeated use, our line of EPDM caps and plugs are perfect for temperatures up to 475 F and are a more economical solution than silicone. They also offer better chemical resistance.

Silicone Rubber Caps and Plugs – The ultimate in masking materials, silicone rubber offers ultra-high temperature resistance, up to 600 F, and reusability, all in one.

Polyester/Polyimide Tapes and Discs – We offer both materials in both styles for masking of flat surfaces. Polyester material will resist up to 425 F for up to one hour, while the polyimide material will resist over 500 F for up to one hour. These tapes and discs can be removed easily and will not leave behind any residue.

Silicone Rubber Tape – Our self-fusing tape will conform to any standard or irregular shape and works excellently as a custom mask. The tape will stretch up to 300 percent and has no adhesive, so it is safe for temperatures above 500 F.

Silicone Tubing – The silicone tubing is sold in coils and works with any high temperature environment. It resists temperatures up to 500 F and can be cut easily at your facility to the length required for your application.

Contact Information: Please visit our website at www.mocap.com or do not hesitate to contact our sales staff for free samples, pricing, or to learn more about our products/processes. Email us at sales@mocap.com or call us at **1-800-633-6775**.

MOCAP[®] MASKING SOLUTIONS

High Temperature Caps, Plugs, Tapes & Discs for Protection, Finishing & Masking



800.633.6775

www.mocap.com

sales@mocap.com



CANADA'S SOURCE FOR NEWS & INFORMATION IN SURFACE FINISHING

By Bob Smith

Welcome to the first edition of our CASF NEWS in 2021. Our hope is that you and your family and friends had a safe and enjoyable passage through Christmas and the New Year and are looking forward to a return to some normalcy of life in the weeks to come.

Here at CASF, we have already begun with the initial work on our ONLINE CASF "Introduction to Electroplating" Course. As you remember, we ran this course in November 2019 for a class of 23 over a full day-and-a-half with a short exam to round it off and the feedback was excellent with most passing. We felt good about contributing to the education and careers of those who attended. Due to COVID we are going to repeat the course online, making it available to those all across Canada from their workplace or home and details will follow shortly on our website. We are also working on our golf tournament, scheduled for September 21, and although it's still a long way off we believe there's a lot of pent up demand building after the year we've all just gone through!

In our last column we promised to begin serializing the Orr & Boss "Surface Finishing in Canada Impact Study" we commissioned in late 2019 and completed in the summer of 2020. A survey of this type has not been undertaken in Canada for so many years that what we had now bears almost no relevance in today's world. Orr & Boss Consulting Inc. had undertaken a similar study recently for the Canadian Paint and Coatings Association, (CPCA), and came highly recommended by Gary LeRoux, CPCA President, so we asked Orr & Boss to review our own market and produce this impact study. In this edition you will find the Executive Summary beginning below and in following editions of CFCM magazine we'll move into the body of the report. We hope you find it interesting and valuable. We guarantee the size and impact of your Canadian surface finishing industry will surprise you!

Executive Summary: Orr & Boss Impact Study

The surface finishing industry includes a wide array of products that are used to finish metal, ABS, polypropylene and nylon resins and in the case of powder coating, wood and other substrates. Electroplating, anodizing, coating, galvanizing, and heat treating metal and plastic substrates fall into this segment. Specialty finishes produced by the surface finishing industry become key components of many products used in everyday life around the world. Surface finishers supply into the automotive, oil & gas, agricultural, aerospace, defense, building & construction, medical, electronics and many other sectors. As such, it is a key industrial market in Canada and helps Canada maintain its manufacturing competitiveness.

The surface finishing industry plays an important role in the Canadian economy by contributing a significant amount of economic activity and supporting other manufacturing industries within Canada, like automotive and aerospace and almost everything else. It extends the lifetime and durability of finished parts, and by doing so, improves the sustainability and environmental performance of its sector within Canadian industry. Moreover, the

surface finished parts, in addition to any cosmetic enhancements, do not wear out or corrode as easily, and thus contribute to improved esthetics, safety, performance and life. This is especially true in the automotive and aerospace industries. Finally, the supply chain for surface finished products is global and the Canadian surface finishing industry produces significant exports. Many parts that are surface finished in Canada are exported to the United States and globally.

The industry is a noted facilitator of economic activity in Canada. Parts to be surface finished are either produced within Canada or imported into Canada, surface finished, and then either consumed within Canada or exported. The exporting of products from the Canadian surface finishers is important in a number of areas, creating and maintaining jobs within Canada as well as generating economic activity and tax revenue for the government of Canada.

While the surface finishing industry touches a wide variety of products and industries within Canada, it is often overlooked as a driving economic force. With an annual impact of \$3.5 billion, just about every manufacturing industry in Canada is touched by the surface finishing industry. Surface finishing adds value to many products, with enhancements related to aesthetics, performance, durability, and lifespan. This report focuses on the economic impacts of the surface finishing industry and reveals the multi-dimensional nature of this sector in Canada.

The surface finishing industry generates significant employment, in excess of 17,198 jobs, which tend to be higher paying jobs than those in other industries. The surface finished products touch many end-use markets and in many of these end-use applications, surface finishing is critical to the success of that industry. One example of this is functional, (hard), chromium. Without it there would be no shock absorbers on vehicles, no hydraulics for construction equipment, no drilling for oil or water, no landing gear for aircraft, and much more.

This industry is one of the most heavily regulated in Canada. The use of chemicals and need for sustainable business practices is critical to the success of the industry, and, as such, the surface finishing industry continues to work with its supplier base and others to invest in new technologies by developing new product formulations that are more environmentally friendly. A strong surface finishing industry is considered important to maintaining and improving Canada's overall economic performance, and that strength is reflected in the contribution to Canada's Gross Domestic Product (GDP) estimated at \$1.31 billion annually.

Economic impacts are defined as changes to an economy as a result of a specific undertaking or activity. With those activities come benefits impacting the size and structure of an economy. This happens as goods and services are produced and purchased, resulting in direct inflows of capital for construction of new facilities or delivery of new and better services. Economic output relates to the gross revenue of goods or services produced by an eco-

economic sector, while GDP measures the value of goods and services produced. The “output” of goods noted in this report is defined as goods produced or imported and sold in the Canadian market. It also captures economic activity generated by exports, though exports represent less than 10 percent of the total volume.

A summary of the economic impact of the surface finishing industry in Canada shows:

- Annual Direct and Indirect Output of \$3.5 billion.
- Surface Finishers Revenue of \$2.5 billion.
- Total Direct and Indirect Estimated Employment of 17,198.
- Total Direct and Indirect Wages and Salaries of \$705 million.
- Wages and Salaries that are 26 percent higher than the Canadian average.
- Annual Induced Employment of 29,924.
- Total Induced Wages and Salaries of \$996 million.
- Annual Federal and Provincial Tax Revenue of \$447 million.
- Annual GDP Impact of \$1.31 billion.

Ontario, Alberta, and Quebec are the main beneficiaries of the economic activity generated by the industry, with nearly 90 percent of the economic activity in those three provinces.

Table 1.1: Summary of Economic Impact of Surface Finishing

conomic	Direct	Indirect	Total Eco- Impact
Output (millions \$)	\$ 2,586	\$ 930	\$ 3,516
Wages & Salaries (million \$)	\$ 636	\$ 69	\$ 706
Employment (Number of jobs)	15,121	2,077	17,198

Table 1.2 Summary of GDP and Taxes Paid by Province (Millions of \$)

Taxes Collected		Total Total GDP
Ontario	\$ 743	\$ 241
Alberta	\$ 248	\$ 65
Quebec	\$ 165	\$ 80
British Columbia	\$ 80	\$ 30
Manitoba	\$ 21	\$ 11
Saskatchewan	\$ 33	\$ 11
Atlantic Canada	\$ 25	\$ 10
Total	\$ 1,314	\$ 447

In addition to the above economic activity, a related segment is the paint and coatings industry where metal and plastic parts are coated. In 2017, the Canadian Paint & Coatings Association (CPCA) engaged with Orr & Boss on a study of the economic im-

port that the paint and coatings sectors have in Canada. The surface finishing and paint and coatings segments are similar since they serve or share similar markets, and both involve coatings or surface finishing of a metal or plastic part. If we include the economic impact of all industrial applied coatings, (in other words, excluding site-applied coatings like architectural, auto refinish, protective, and marine coatings), the economic impact is:

- \$3.03 billion of output
- \$702 million of wages and salaries
- 21,240 jobs created
- \$1.148 billion of GDP
- \$428 million of tax revenues

It should be noted that the above values for industrial applied paint and coatings include all industrially applied coatings including automotive OEM coatings, coil, general industrial, metal packaging, powder, and transportation coatings (rail, aerospace, and others).

Table 1.3: Economic Impact of Industrial Applied Paint & Coatings

conomic	Direct	Indirect	Total Eco- Impact
Output (millions \$)	\$ 1,109	\$ 1,921	\$ 3,030
Wages & Salaries (million \$)	\$ 222	\$ 480	\$ 702
Employment (Number of jobs)	5,276	15,965	21,240

Table 1.4: Summary of GDP and Taxes Paid by Province (Millions of \$) of Industrial Coatings

Taxes Collected		Total Total GDP
Ontario	\$ 671	\$ 251
Alberta	\$ 105	\$ 39
Quebec	\$ 164	\$ 61
British Columbia	\$ 110	\$ 41
Manitoba	\$ 35	\$ 13
Saskatchewan	\$ 22	\$ 8
Atlantic Canada	\$ 37	\$ 14
Total	\$ 1,144	\$ 428

If we add in the contributions of the Surface Finishing and Industrial Paint & Coatings Market, the total result is:

- Output of \$6.5 billion
- Wages of \$1.4 billion
- Employment of 38,438
- Total GDP Impact of \$2.5 billion
- Total Taxes Collected of \$876 million

These data are summarized in Tables 1.5 and 1.6.

Table 1.5: Economic Impact of Surface Finishing & Industrial Applied Paint & Coatings Segments

	Direct	Indirect	Total Eco-
conomic			Impact
Output (millions \$)	\$ 3,695	\$ 2,851	\$ 6,546
Wages & Salaries (million \$)	\$ 858	\$ 6549	\$ 1,407
Employment (Number of jobs 1000s)	20,397	18,041	38,438

Table 1.6: Summary of GDP and Taxes Paid by Province (Millions of \$) of Surface Finishing and Industrial Coatings

Taxes Collected		Total Total GDP
Ontario	\$ 1,413	\$ 492
Alberta	\$ 353	\$ 105
Quebec	\$ 329	\$ 142
British Columbia	\$ 191	\$ 71
Manitoba	\$ 56	\$ 24
Saskatchewan	\$ 54	\$ 19
Atlantic Canada	\$ 62	\$ 24
Total	\$ 2,458	\$ 876

The Canadian surface finishing industry has proven to be strong and resilient. A highly regulated sector, the surface finishing industry has shown tremendous responsibility in cooperating with all levels of government to ensure products are safe to human health and the environment. It does this while still performing to the standards expected by its customers and improving the economy's overall sustainability record by increasing the durability and lifetime of the surface finished part. As a direct result of these value added activities, consumers' cars last longer, airplanes are safer, consumer electronics perform better, the oil, gas, and mining industries are more efficient, and the Canadian economy is more durable and productive — all as a result of the surface finishing industry.

In addition to cooperating with all levels of the Canadian government, the surface finishing industry must and does comply with regulations around the world due to the global nature of the product. Good examples of these are the EU REACH regulation and the RoHS Directive. Since many surface finished parts are used in the EU, many Canadian surface finishers must also ensure that their products comply with the REACH regulation and/or the RoHS Directive.

CASF has worked closely with all levels of government in Canada and in committees to help develop appropriate regulations for the industry and promote compliance with existing regulations, thereby ensuring a strong, sustainable and environmentally compliant manufacturing industry in Canada. ■

Bob Smith is Past President and Membership Chair, Canadian Association for Surface Finishing (CASF), www.casf.ca

2021/22 BUYERS GUIDE

A MUST BUY for suppliers to the Canadian market of:

- Paint and Coatings for Industrial Finishing
- Equipment and Services for Industrial Finishing
- Metal Finishing Supplies for Anodizing, Plating and PVD
- Metal Finishing Equipment
- Paint and Coating Raw Materials, Supplies and Services
- Paint and Coating Manufacturing Equipment
- Custom Coaters and Job Shops
- Associations, Education and Government

Go to www.cfc.ca and click on Buyers Guide to place your new free listing or update your current listing.

RESERVE YOUR AD TODAY!
ADVERTISING SPACE CLOSES: JUNE 1
MATERIAL DEADLINE: JUNE 8



Associate Publisher & Sales: Gillian Thomas
 • 1-416-277-1269 • gillian.thomas@cfcm.ca
Editor: Theresa Rogers
 • 1-416-201-1975 • theresa.rogers@cfcm.ca

www.cfc.ca

Dynamix is proud to be the largest Canadian-owned manufacturer and supplier of surface finishing chemistry. 2021 will mark the 15-year anniversary of Dynamix supplying automotive, energy, aerospace, RoHS, ELV, WEEE, and REACH compliant metal finishing products right across North America. Dynamix was established in 2006 with the goal of being the #1 choice for the surface finishing chemistry. The leadership group share more than 75 years of finishing experience in real-world facilities. The combined knowledge of technical service, laboratory service, research and development, manufacturing, ISO 9001:2015, marketing, and sales, enables Dynamix to provide high quality products and cost-effective solutions for any problem, to all customers. In a competitive marketplace this gives customers an operational advantage.

Our Philosophy

“The philosophy at Dynamix is simple – enhance our customers’ performance and profitability, while dealing with all of our partners in an open and honest forum.”

Main Focus

The primary focus of Dynamix is the design and manufacture of specialty chemicals for the metal and surface finishing industries covering all aspects of metal finishing; anodizing, galvanizing, electroplating; pre-paint treatment, etc. We pride ourselves on our ability to adapt to a challenging market and meet extensive customer demands by providing the most robust chemical processes available. Custom compounding, toll blending, private label packaging, third party logistics, and distribution are also available.

Distributing Partners

Dynamix understands that from a research and development perspective you can never be the best at absolutely everything. For those areas, Dynamix has partnered with some of the industry’s best. Distributing products for their partners allows supply of a wider variety of chemistries, including automotive and aerospace approved products.

Our Strength

Dynamix’s strength is in electroplating. What sets it apart from the competition is the ability to conduct its own research and development and manufacturing here in Canada. This enables Dynamix to tailor make solutions to any problem.

Dynamix offers a service that encom-

passes all its values with a highly skilled and motivated team. The laboratory at Dynamix is well equipped and able to provide analytical solutions specific to a particular sector of industry and/or customer.

The company has two locations: Markham, ON, and Montreal, QC.

Products are designed to provide unsurpassed performance and solution economy. Superior chemistry is only the

beginning, as the company realizes technical and application knowledge are just as vital to the metal finishers’ success.

Ask a representative at Dynamix about the full line of proprietary products or enquire about a custom-blended product. All products are developed with your business success in mind.

Contact www.dynamix-inc.com today.

Specialty Chemicals for the Surface Finishing Industry

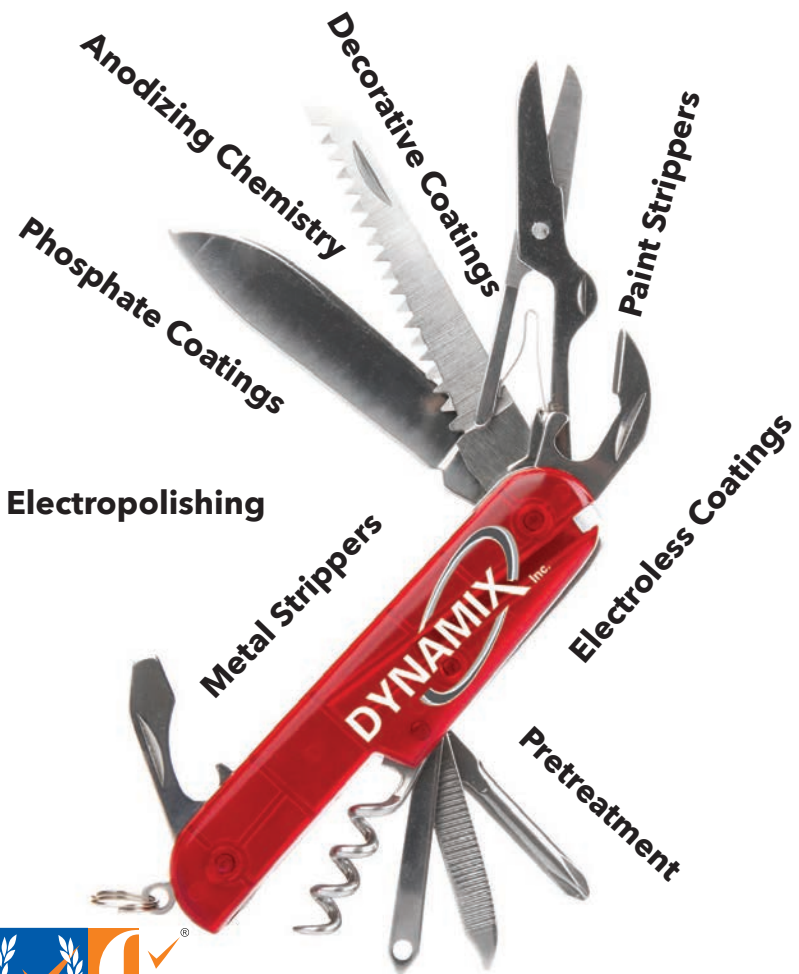

www.dynamix-inc.com

91 Esna Park Drive, Unit #7
Markham, Ontario L3R 2S2
Phone: (905) 477-0900

THRIVING AVIATION INDUSTRY EVOKES DEMAND FOR AEROSPACE COATINGS

By Global Market Insights

A global behemoth, the aerospace industry has come out strong as a profitable business sphere over the past few years, both in terms of revenue share and developments. The Canadian aerospace industry contributes about \$25 billion in GDP and hundreds of thousands of jobs to the economy.

By the end of 2018, the U.S. aerospace industry boasted of foreign direct investments (FDIs) of almost US \$22 billion. The sector as a whole has been proliferating at a steady pace over the last decade or so. Obviously, this will provide a major boost to the demand for aerospace coatings.

It is no secret that aerospace sector is one of the demanding industries for coatings and materials. Aerospace Coatings – as well as paint technology – offer high-end protection from corrosion, UV radiation, erosion, abrasion, and more in the most extreme conditions. The aerospace coating market is set to record phenomenal gains in the years ahead because of its strong role in the overall aerospace and defense industry, and for its winning business strategies including mergers and acquisitions, product diversification, partnerships, and others.

Powerful industry players like BASF, Akzo Nobel NV, Heinkel, PG industries, and The Sherwin Williams Co., are leaving almost no stone unturned to leverage the opportunities coming their way, making the global market a lucrative business hub.

Billion-dollar Aerospace Industry to Form a Pivotal Growth Ground for Canada Aerospace Coatings Market

Speaking of the significance of aerospace coatings across Canada, it is pivotal to understand how crucial the aerospace industry is for the country. According to the Aerospace Industries Association of Canada and Innovation, Science and Economic Development Canada, the aerospace industry valuation in the region, in 2018, stood at an impressive US \$31 billion, and contributed over US \$25 billion to the national GDP and more than 213,000 jobs in the Canadian economy. Around 70 percent of the industry's activity is dedicated toward manufacturing while the remaining concentrates on MRO (maintenance, repair and overhaul).

Expanding aircraft production and rising passenger traffic are likely to offer a significant boost to the overall industry share over the coming years. In turn, this will boost the aerospace coatings industry in Canada.

The Canadian government has been bringing about various reforms as well as novel strategies to enhance the development of aerospace coatings facilities across the country.

In 2018, the federal government and the Atlantic Canada Opportunities Agency (ACOA) announced a whopping US \$3.2 billion investment in leading aerospace company MDS Coating Technologies. As per news reports, the funds have been utilized to



pave way for new manufacturing operations and technology for the firm's specialized coatings and polishing for aerospace engines.

In addition to the power pact investment, ACOA's business development program was also reported to offer US \$200,000 to bolster MDS Coating's purchase of a 3D metal printer to support novel manufacturing techniques. As per credible sources, the company's coating technology has drastically reduced engine maintenance costs, greenhouse emissions, and fuel consumption, acting as a perfect solution for all coating needs across the aerospace industry.

Numerous Developments in Aerospace Coatings to Revolutionize the Business Space

Lately, the aerospace coatings market has been highly characterized by a host of modern innovations, mainly influenced by the global sustainability trend. This has been particularly observed across North America, which hosts a number of aerospace manufacturers. Industry leader PPG International's recent development of 'PPG AERCON aerospace electrocoat primer' for the U.S. Air Force is one example. With highly anticipated testing being conducted at the Air Force's Advanced Technology and Training Center in middle Georgia, PPG primer is said to offer superior corrosion resistance and enhanced topcoat adhesion for aircraft parts.

Reports suggest that the U.S. Air Force issued a bulletin last October to declare the primer's vitality and significance for coating parts used on the outer surface of aircraft. Once thoroughly tested for use, the coating is expected to become a subject of pursuit amongst investors which would bring a dynamic disruption in the overall aerospace coatings industry to watch out for.

|||||

Powerful industry players like BASF, Akzo Nobel NV, Heinkel, PG industries, and The Sherwin Williams Co., are leaving almost no stone unturned to leverage the opportunities coming their way, making the global market a lucrative business hub.

|||||

A major concern that has been laying massive influence on the growth projections of aerospace coatings market is the aircraft weight. Building a lighter aircraft is generally beneficial for the aircraft operations and the environment. Reducing weight can lead to enhanced fuel savings, in turn adding to increased financial and sustainability performance.

In light of this issue, PPG has developed and commercialized several products that are anticipated to deliver weight-saving solutions to its customers. In 2018 the company announced launch of Desothane HD basecoat clearcoat, which enables customers to reduce the weight of coatings on their aircraft nearly 20 percent. It is safe to say that a lightweight aircraft body has emerged as one of the most prominent trends across the aerospace coatings industry.

Lingering Effects of the Coronavirus Pandemic on Aerospace Industry and Aerospace Coatings Market Worldwide

The coronavirus pandemic has had a major impact on the global economy while also paralyzing various industries including aviation. As fleets are grounded, the demand for paints and coatings products has substantially decreased. However, since lockdowns across various economies will all lift in time, manufacturers and industry giants have been laying the groundwork for much-desired focus on hygiene in the aircraft cabins, offering newer growth opportunities.

Mankiewicz Coatings, for example, developed a paint equipped with antimicrobial additives. ALEXIT FST BioProtect, is a coating that uses silver technology to curb the growth of bacteria and mildew on surfaces painted with it. Such innovations are likely to help increase the company's overall market valuation and ensure customer satisfaction.

Aside from North America, the aerospace coatings industry is also poised to see big gains across Europe, Asia Pacific, and Latin America. Asia Pacific has come out to be one of the strong growth avenues for the overall aerospace coatings market owing to the rising international trade across India and China, and increasing air traffic. ■

*Prepared for CFCM by Global Market Insights
www.gminsights.com.*

HOW AUTONOMOUS ROBOTICS TECHNOLOGY ENABLES A RETHINK FOR AEROSPACE COATING PROCESSES

By Robert Ravensbergen

Finishing and coating processes are in part so demanding because they are so visible. Customers and end users for products expect consistent and defectless outputs for new or refinished products and hence expect parts or finished goods to be flawless upon delivery.

The scale of customer expectations isn't the only coatings challenge specific to the aerospace industry either. Specific measurements and compliance needs make each process tedious and unique, which becomes all the more difficult in the face of continued shortages in the highly refined skilled labor to meet production goals.

While automation solutions exist for coatings – whether using reciprocating arms or robotization in high-volume operations – the automation is rarely flexible enough to meet the precise demands found in aerospace parts. Low-programming solutions like an automated booth don't adapt enough to concave or complex part shapes, and still produce rework, while robotic solutions that require extensive programming will rapidly become too expensive as changeover becomes more frequent.

In this circumstance, autonomous robots may offer a way forward for high-compliance, high-mix coatings processes. Much the same way autonomy is bringing new efficiency to self-driving cars and materials handling, autonomous technology for value-added processes can effectively drive a process forward to achieve maximum consistency and productivity without the wait – the technology is already available today, thanks primarily to the constraints and specific needs of value-added processes which permit a market-ready solution to be more rapidly delivered. In all cases, this enables a rethink of coatings processes. Not just on consistency and quality improvements, but also on the variety and order of parts coating, improved efficiency across finishing lines and the ability to specify parts within value-added processes.

Consistency and Quality Improvements

Autonomous robots generally require one input – a goal set – and the subsequent resolution of three core problems: localization, planning and manipulation. A goal could be “pick up that cup and put it on the table across the room”.

Localization would then refer to the robot's ability to identify its own coordinates in a given known and unknown space, as well as the location of objects that are subject to the goals set for it. Planning refers to the ability for the robot to take obstacles, constraints or preferred methods into account in how it sequences actions that

then proceed to its goal. Manipulation – in this case we're truly thinking of “C3PO” type machines – refers to how the robot would, in our example, pick up the cup, carry it and place it down again.

In the case of autonomy for value-added processes, localization specifically requires an identification of where the robot and the part being processed are placed. The planning involves process constraints and the manipulation involves the execution of action on a spray gun or nozzle to achieve a specified outcome.

Obviously, a range of understanding can apply here, but in the case of spray finishing processes, precision is usually not required below one millimeter for accuracy approximating that of a skilled human operator to be achieved. With advances in a variety of technologies, including sensor fusion, multiple 3D sensors can be used to simultaneously identify the position, shape and orientation of complex shapes and parts – including concave parts.

In this case, where the “loop is closed” and all sensor data is connected to a robot equipped to generate its own motion program – the same way a self-driving car has the processing power to know when to turn left or right – a robot can subsequently plan out operations to maximize the probability of a consistent output. Instead of behaving the way a human does, where a loose plan or methodology might be subject to change, a robot can adhere to specific instructions in an unpredictable band of scenarios with the same “robotic” precision that robots are of course known for.

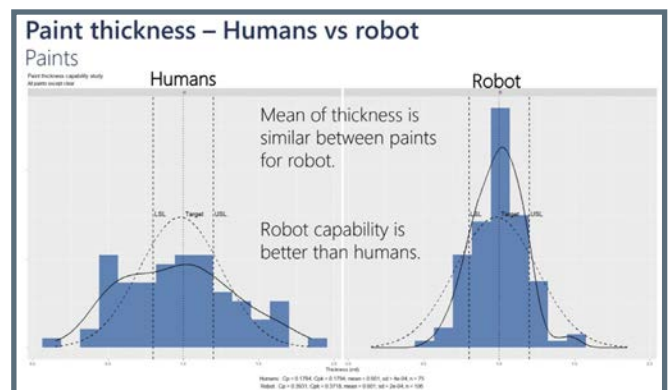

Above is data from an internal study at an aerospace manufacturer. Autonomous robots can function on a variety of parts with a much higher degree of consistency than a skilled human operator – not just in degrees of thickness but also in consistently achieving full coverage of a part without added time or review.

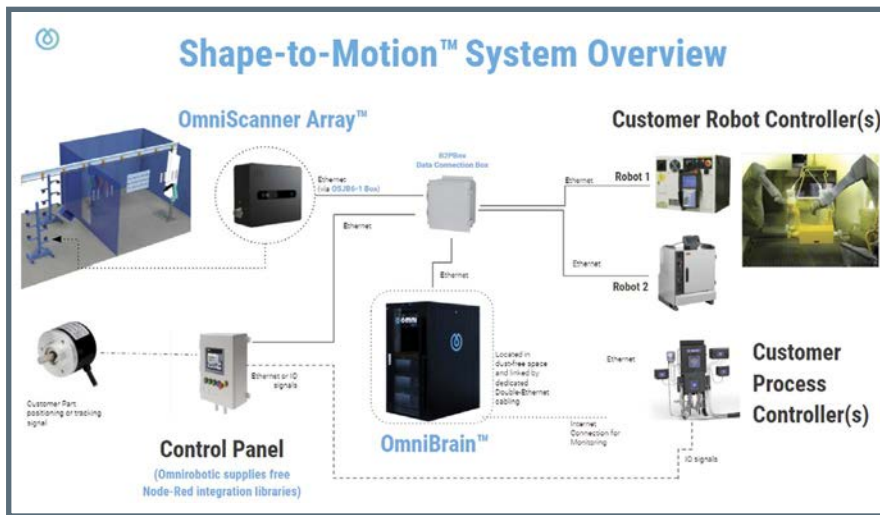

Omnirobotic's Shape-to-Motion Technology provides a systemic approach to integrating autonomous robots for spray processes. By reducing the costs of integrating and making it possible to function in a variety of workflows – whether it's standalone paint booths or overhead conveyors – both the efficiency and payback of the technology is accelerated.

Reduced Limitations for Jigging and Workflow

In order to truly reduce the cost of integrating robotics for finishing processes, a robot must be able to step into an existing coating booth and conduct a process in a way that justifies any added cost over existing workforce or equipment. In this case, a robot can produce significant cost savings – whether it's on productivity lags or bottlenecks, labor inefficiencies or consumables and energy savings – hence justifying the added cost is simple if the system is practical to integrate.

In the case of autonomous robots, given the “low-profile” of sensing capacity, there are few limitations on where a sensor can be integrated. Because most robot models don't exceed the spatial limitations of an everyday paint or coating booth, the combination of low-profile sensors and compact six-axis robots means there are limited added costs to incorporating a robot beyond the cost of the hardware itself. This is in stark contrast to traditional, manually programmed robots, where environments must effectively be designed around them in order to ensure nothing is out of place that may defeat the motion program and also to ensure that the motion program is accurately applied to the part being processed.

This reduced jigging and workflow limitations have another unique added-value: the ability to eliminate many of the costs that come with advanced automated coating booths, particularly for applications like powder coating. Many of these installations can cost north of \$1 million, with three-axis coating booths allowing for quick manual programming on complex parts, but still often requiring rework on initial capital investment.

If you already have a finishing or coating operation, then you probably have a booth. This means that, aside from building the booth itself, you face hardware costs of \$50-75,000 up front, and while peripherals may need to be replaced every few years, many industrial robots are built to function for upwards of 20 years with minimal maintenance. As an initial capex, the savings are tremendous, especially when compared to limited rework on the backend.

Increase Efficiency in Multi-Process Finishing

Ultimately, as the localization and manipulation processes are figured out, the planning aspects of an autonomous robot can take a step beyond what finishing processes typically apply and allow for

the fundamental “rethink” that most finishing departments may want to achieve, or simply need to achieve to exceed their goals.

In this case, task planning can use a few components: in the context of a Digital Twin of the environment (which includes the 3D perception of any part processed), process knowledge, task knowledge and motion ordinarcing can all be used to “chunk” the various subroutines of a given process and then assemble them in the most efficient A-to-Z sequence possible.

In this case, process knowledge can apply to things like faraday caging in powder coating or drip risks in liquid coating. There are common strategies that experienced coaters use to avoid the downsides of these particular effects, but when a robot is trained to account for them as well, it can ultimately limit any form of rework required beyond the typical consistency and quality of final coating a robot can achieve.

The implication here is that, in the case of high-precision or compliance-driven industries, much finishing work also comes down to “refinishing”: exhaustive inspection of parts, added coatings, reducing or modifying thickness or reflectiveness, inspecting and effectively going in a Boolean loop with all these activities until a satisfactory output is achieved.

Process knowledge and expertise can overcome not just some of the “know-how” limitations that robotics typically face, but it can actually bridge gaps and exhaustive, multi-stage rework-inspect-rework processes by achieving such a consistent and reliable output with the addition of exact process specifications. As such, the productivity gain reaches beyond a simple basic improvement in output to an entire rethinking of process capabilities.

Part Surface Specification Within Value-Added Processes

Finally, because the “instruction” problem is easily solved with autonomous robots, they don't just respond to a variety of never-before-seen parts with maximal consistency, but they also enable advanced recognition and specification to be rolled into their process know-how.

For instance, CAD files of known parts can be used to generate recognizable 3D perceptions of shapes as they are seen, tying the CAD file to the shape. Then, within the same software interface

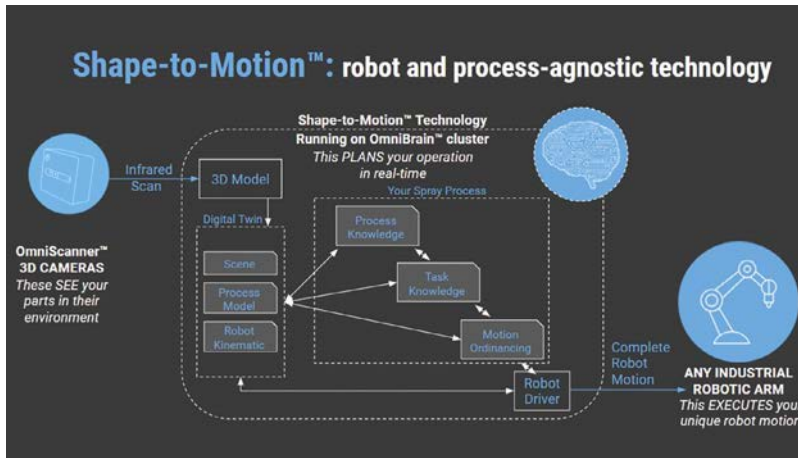

Omnirobotic's Shape-to-Motion platform provides an example of how process know-how can be incorporated in the planning component of an autonomous robot. Because spray processes have such a wide variety of know-how to incorporate, autonomous robots are uniquely suited to accelerate the value and payback generated in spray processes.

demanding physical labor – and extensive physical hazards – of coating operations can be avoided, making jobs more dynamic, more attractive and more self-directed in ways that today's young workforce appreciates.

In the case of aerospace coatings in particular, this is useful due to the great detail of parts which means that allowing a CAD file to be used for processing can eliminate any imprecisions that might still make their way into a robotic system. Finally, by being able to specify part surfaces, different specific goals can be met depending on where a part is placed in final assembly, “which coatings go where” or in delivering particular attention to certain part faces during MRO processes. In all cases, adaptable, autonomous

robotics technology becomes a new tool that radically alters how spray processes can be organized and goals can be achieved.

Where “Rethink” Escapes “Groupthink”

The core benefits of autonomy come in the ability to escape the intensive requirements of programming, jiggling and rework and instead have something “done for you”. The base value of this is tremendous, but the strategic value that comes in being able to rethink how spray finishing processes are planned and executed – in as much as they require any human planning and coordination at all – cannot be underestimated.

Even in the midst of pandemic-driven unemployment, skilled labor positions remain unfilled. Demographic changes mean that more experienced workers will be leaving the workforce than ever before, while their experience will hardly be replaced in sufficient time to not pose additional training, extensive rework and broad retention costs on industry as a whole, much less finishing departments in particular.

At the same time, mass customization trends may be showing that purely manual robotic programming can't sustain even the largest manufacturers. Products need to be more differentiated than ever in order to sell. Customization is a part of that, but achieving customization with limited added costs is what consumers and business clients will truly respond to. Autonomous robots provide a gateway to achieving this. ■

Robert Ravensbergen is the Marketing Director at Omnirobotic, the only provider of AI and 3D vision-based autonomous robotics technology for high-mix industrial spray, coating and finishing processes. Learn more at www.omnirobotic.com.

that is used to identify the process know-how to be engaged, faces and surfaces of parts can be specified and – even in conveyor scenarios – be instructed to be painted each by a particular robot with a particular color or type of coating already loaded up.

In this circumstance, automation is more rapidly achieved for both high-mix and customization-driven manufacturers. Furthermore, by reducing the role of a paint gun operator to software operator, material loader and quality inspector, much of the most



More common to the aerospace industry, this type of batch booth layout allows aerospace coaters to specify every aspect of a process no matter the series of small or tedious parts required. At the same time, the operator is removed from a hazardous environment and able to manage a machine that generates maximal consistency.

Therma-Tron-X, Inc. designs, fabricates, and installs innovative, custom paint finishing systems for contract shop coaters and OEMs. TTX manufactures over 90% of the equipment that goes into each system and offers turnkey services including multi-stage pretreatment equipment using spray, immersion or a combination; industrial ovens fitting desired spatial needs and utility requirements; environmental rooms offering ideal powder paint application conditions; liquid spray booths balancing airflow and minimizing overspray; and material handling solutions designed to fit individual needs. TTX fabricates equipment in their plant as complete as it can be shipped, already wired, piped, and tested as much as possible. Installation supervisors are on the job for the entire installation.

TTX Environmental (a division of TTX) focuses exclusively on industrial water and wastewater treatment products, paying close attention to changing regulations and new environmental concerns. Engineers from TTX ENV evaluate wastewater streams before recommending the best wastewater system for the customer. A wide variety of modular system components are easy to install and provide flexibility for future expansion.

From start to finish, TTX will automate every step and integrate their equipment with the facility.

TTX's newest innovation, the Automated Conveyor Carrier (TTX ACC®), is a flexible overhead, battery powered, individually programmed conveyance system that consists of carriers that provide reliable and consistent

point-to-point movement of everything from small to heavy parts. The ACC®'s utilize a wireless network to send instructions to individual carriers throughout the paint lines and are hung on an overhead I-Beam rail that uses an adjustable friction drive wheel to maneuver. TTX's revolutionary SLIDERAIL SQUARE TRANSFER® (SST®) material handling system performs high volume finishing operations using a fraction of the space required traditionally. Monorail, Power and Free, and custom conveyor systems carry parts through paint application processes while fully automating manufacturing facilities and efficiently transferring product between manufacturing, finishing, and final assembly/shipping areas. Programmable hoists are custom designed and built to serve wide varieties of industrial finishing processes and can be integrated with multiple styles of conveyor systems.

Successful companies rely on TTX's knowledge and experience in coating technologies, equipment development and water and wastewater treatment solutions. Research and development, innovative designs, quality workmanship, project management, and superior service bring customers from all over the world to TTX's doorstep.

Visit our website to learn more about our products.

Therma-Tron-X, Inc.

(920) 743-6568

www.ttxinc.com



Therma-Tron-X, Inc.

Your Best Finish Starts With Us!

TTX designs, fabricates and installs custom industrial finishing systems for industrial clients. From inspiration to design, from design to application, TTX's experienced engineers are focused on your project.

Services:

- Creative Evaluation
- Innovative Design
- Fabrication
- Installation
- Start Up & Testing
- Field Work

www.ttxinc.com | sales@ttxinc.com

CASE STUDY: FLEXIBLE LACQUERING WITH ROBOTICS

By Alexander Hunger

A new multi-purpose Venjakob lacquering system was put into operation for a service provider specializing in aerospace industry coatings. The system is suitable for coating screw threads as well as flat and rotationally symmetrical parts.

Aero-Coating GmbH in Wismar – an affiliate of Eifeler-Holding GmbH & Co. KG based in Düsseldorf/Germany – coats components made of metal or polymer materials with functional layers against contact corrosion for businesses mainly in the aerospace sector.

Flexibility as an Essential Requirement

For years, the components were mounted on special carriers and manually coated. However, this limited the throughput capacity and the finish quality was not reproducible.

For this reason, the decision was made to invest in a coating system. A very specific requirements profile was created which presupposed a “dual” and particularly flexible application since Aero-Coating coats screw threads in high volume, but also flat 3D and rotationally symmetric parts.

Lacquer Booth with Two Loading Possibilities

The company also desired a compact total system as an island solution with a structured design of the individual assemblies – handling and transport, application robotics, spraying system and booth housing with exhaust and supply air components. The control and formula management was supposed to be mostly automated and operation of the robot based on simple programming via copy-



The carrier system is suitable for components of various sizes and shapes. The system offers high performance due to the parallel use of two linear axes.

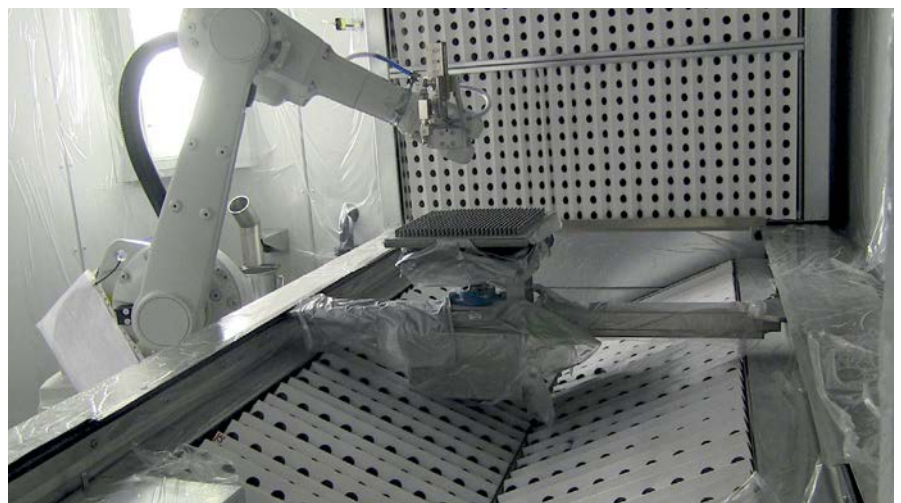

A rotary table allows the coating of flat and rotationally symmetrical parts. The robot needs approximately one minute for the coating of the workpieces.

ing programs and changing parameters. High reproducibility in terms of performance and the quality of the coating was desired (uniformity/evenness of the lacquer application while adhering to the coating thickness tolerances).

Venjakob created a two-in-one robot application solution – a coating booth with two loading possibilities.

Mode A: Loading with Workpiece Carrier

In the first operating mode, loading takes place via a special workpiece carrier. The carriers are manually filled with screws, further conveyed in cycles and transported into the spraying booth via linear axes. A tray is lacquered and complete within 12 seconds.

Two linear axes that operate in parallel guarantee high system performance. While one of the two linear axes lingers with one carrier in the coating booth, the other one moves the finished coated components to the flash-off zone or to the discharge, drops them off and returns to the start position to pick up the next carrier. Because only the thread of the screw is supposed to be coated, the area of the linear axle is sealed off around the carrier system and is provided with overpressure during lacquering. To achieve selective coating and to keep over-spray in the booth to an absolute minimum, the robot is also equipped with a spray marking gun, which can atomize the finest amount of coating.

The carrier plates are outfitted with solvent-resistant RFID chips, which are selected prior to entry into the spray booth. The robot can thus retrieve the respective program automatically. The component carriers are flexibly adapted and are suitable for components in various sizes and shapes, especially for lacquering small parts. A wide variety of components can be coated with this system design, without having to manually intervene.

Mode B: Coating on Turntables

A turntable was installed in the system, whose rotary function can be activated as needed, for coating flat and rotationally symmetrical components. A vertical separating wall simplifies manual loading and unloading.

The machine operator places the loaded workpiece holder on the turntable. A toothed belt conveyor moves it in front of the lacquering robot and after coating moves it back to its original position for removal.

The robot needs roughly one minute in this mode, depending upon the contour of the workpiece, to lacquer the workpiece. The components can have maximum dimensions of 700 mm x 700 mm x 600 mm.



The multi-purpose coating plant was realized in a small footprint.

Compact System

The entire system was realized in a space of only 6 m x 4 m x 3.7 m. A Siemens-S7 control system is operated via touch screen. The lacquer programs are stored there as formulas, which can be retrieved manually or automatically via a RFID chip.

In this case, the system manufacturer and the user worked closely together during project planning.

“The idea for the two-in-one solution came from us, as we don’t expect complete utilization of the thread coating for two years,” says Dr. Florian Gehrig, Managing Director of Aero-Coating. “The second feed system was installed so that in the meantime we can lacquer other components and free up the manual coating booths.”

Venjakob helped realize the design as well as the selection of the paint feed systems, the application technology and the conveyor technology. One special feature, among others, is the reduction from four to just one lacquer spray gun. This cuts costs and reduces the risk of problems with the lacquer supply.

Just Eight Months from Idea to Initial Operation

The entire project took eight months to complete. After the first three months following approval of the concept, Venjakob began design and construction of the system. The entire system was tested at Venjakob one month prior to delivery. Site installation took 10 days and certification by Aero-Coating customers was completed after one month.

“Customers immediately confirmed the repeat accuracy and the consistent quality,” says Gehrig, who himself is thoroughly satisfied with the overall design.

“We were immediately impressed by the entrance into the world of robots. By using robotic systems, we are able to handle the sudden increase of 30 percent in customer demands and at the same time reduce overall throughput times by 20 percent. In addition, the system takes up very little space, and we are using less solvent.” ■

Alexander Hunger is Project Manager at Venjakob, www.venjakob.de/en.

REALITIES IN THE MECHANICAL TUBE MARKETPLACE

By Michael Kelly

Delivering the best product to your end customer is key in today's manufacturing environment and has been a continuing message for North American manufacturing companies. This is not new by any means but is receiving more emphasis and attention as end customers are more involved in their suppliers' manufacturing supply chain.

In the mechanical tube marketplace, this is defined as the following:

- **Reduced overall product cost** – a reduction of overall pricing / measured in reduction of price per linear foot.
- **Continually improved product performance** – increased white and red rust protection / measured by increased hours of ASTM B117 Salt Fog exposure.
- **Embracing a sustainable manufacturing process** – improved sustainability in the manufacturing process would equate to less emissions / measured as an overall reduction in VOCs and HAPs (Volatile Organic Compounds and Hazardous Air Pollutants)

Most of the mechanical tube manufacturers incorporate some type of coating system into their tube manufacturing process. In most cases it is a water-based coating system, utilizing a flood and wipe or vacuum application and some type of air flow and/or thermal drying system at end-of-line, before tube cut-off.

This coating system provides an in-line coating that is applied to the mechanical tube, which delivers enhanced outdoor protection from humidity and temperature during transport, yard storage and end-processing.

In their quest to continue to reduce overall tube costs, the mechanical tube manufacturer must continuously review their internal processes. One of the areas for review has been the type of coating applied to the mechanical tube. So, over the past decade, many mechanical tube manufacturers have reviewed their water-based coatings against UV / ultraviolet coatings solution.

Water-based Coatings

There is a significant number of mechanical tube manufacturers utilizing water-based coatings for their coating needs today. For manufacturing lines running less than 150 feet per minute, the investment cost for implementing a water-based coating line can be lower than a traditional arc lamp UV line. A simple flood and wipe, with induction heating or heated air tubes, will typically do the trick and provide a temporary rust inhibitor for the tube. Utilizing induction heating will greatly reduce the humidity and temperature issues that impact water-based coating applications.

The cost per gallon for water-based coatings is much lower than

UV coatings, since percent solids for water-based range from 18 percent to 30 percent; but you also get less coverage per gallon. This is where the ROI calculator in Table 1 will assist you in understanding coverage per gallon when comparing water-based coatings to UV coatings.

The UV Alternative

Ultraviolet coatings technology offers a unique opportunity to dramatically improve your manufacturing process, improve your sustainability footprint, and deliver actual ROI – less coating cost per linear foot of pipe or tube.

Mechanical tube manufacturers are quick to embrace UV coatings once a detailed cost analysis is completed, as outlined further in this article.

Reduced Overall Product Cost

FUNCTIONAL PIPE COATING MODEL		
Linear Foot Comparison:	1.5	Inches Diameter
Target Coating Thickness	0.3	Mils Thick
Description	Water-based	UV
Coating cost per gallon	\$ 17.40	\$ 66.20
Percent Solids	24.5%	100.0%
Percent Water	75.5%	0.0%
Coverage at 1 mil - Square Feet	393	1,604
Coverage at 1 mil - Square Inches	56,589	230,976
Diameter of Pipe (inches)	4.71	4.71
Linear inches per gallon	12,009	49,015
Linear feet per gallon @ 1 mils thick	1,001	4,085
Linear feet per gallon @ 0.3 Mils thick	3,336	13,615
Cost per linear foot coated specified inch diameter pipe	\$ 0.0052	\$ 0.0049

Table 1: Water-Based – \$17.40 per gallon / 24.5% solids versus UV – \$66.20 per gallon / 100% solids.

The UV coating is less cost than the water-based coating, at roughly seven percent less per linear foot. There is also reduced coating transportation costs, less handling costs, less storage space, etc.

Continually Improved Product Performance

Outlined below are ASTM B117 Salt Fog testing on G40 galvanized mechanical tube pieces. These were tested for 912 hours.



Examples of mechanical tube applications.

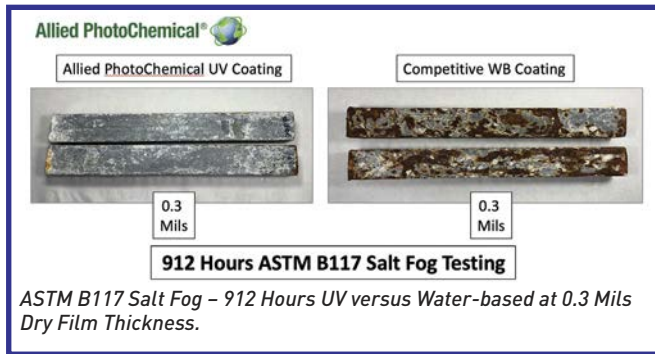

Embracing a Sustainable Manufacturing Process

UV is inherently cleaner than water-based coatings with no VOC or HAPs. Plus, eliminating the handling / exposure of flammable water-based coating on the plant floor makes for a safer and cleaner overall coating operation.

In the example below, the water-based coating contains 1.86 pounds of VOCs per gallon, where UV contains zero pounds of VOCs.

Example: Yearly VOC savings of 108,628 lbs with UV Coatings

FUNCTIONAL PIPE - VOC SAVINGS		
Description	Entered Data	Measurement
Water-Based Coating VOC's / Gallon:	1.86	Lbs / Gallon
Water-Based Percent Solids / Gallon:	24.5%	Percentage
UV Coating VOC's / Gallon:	0.00	Lbs / Gallon
UV Coating Percent Solids / Gallon:	100.0%	Lbs / Gallon
Amount of Coating Consumed:		
Description	Entered Data	Measurement
Water-Based Coating per YEAR	58,400	Gallons
UV Coating per YEAR	14,308	Gallons
VOC COMPARISON - WATER / UV		
Description	Water-based	UV
Percent Solids	24.5%	100.0%
VOC's per coating	1.86	0.00
Amount of VOC's based on consumption	108,624.00	0.00
Total VOC's emissions SAVED per YEAR:		108,624

Table 2: Water-based and UV Coatings - Comparison of VOC – Emissions saved.

UV Process Solution / Equipment

Outlined in the equipment layout below is a small footprint solution for coating mechanical tube with UV coatings. Typically, the galvanized tube is washed and dried, then is coated via a vacuum coater, then cured with UV microwave lights. This takes place in a physical footprint ranging from 22 to 28 feet.

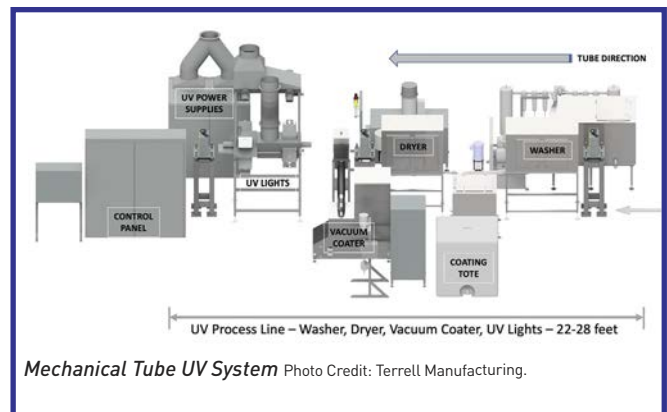

Conclusion

If nothing else, the COVID-19 pandemic re-emphasizes and reinforces the importance of a stable supply chain. Delivering the best product to the end customer is key in today's manufacturing environment.

In the mechanical tube marketplace, reduced overall product costs, continually improved product performance, a lower physical equipment footprint in the manufacturing plant, and a sustainable manufacturing process, all combine to achieve these goals. ■

Michael Kelly is Chief Customer Officer, Allied PhotoChemical, Inc. www.alliedphotochemical.com He can be reached at mkelly@alliedphotochemical.com.

Spray the right amount, in the right place, at the right time

SAMES KREMLIN is a world leader in precision spraying solutions. This powerhouse has behind it a century of innovation in both liquid paint and powder spraying.

SAMES KREMLIN offers complete solutions from pumps to full application systems. We are designers and manufacturers of process equipment in six product ranges:

Airless: We provide premium Airless products for finishers with demanding applications.

Airmix: We have been the creators of Airmix since 1975, bringing the perfect mix between quality and productivity.

Airspray: We have been an Airspray manufacturer since 1925, bringing you the very best in finishing.

Rexson Dispense: Pumping beyond the possible and dispensing precisely.

Powder Coating: For the highest productivity since 1960.

Electrostatic: Expertise for high finishing quality and efficiency.

We recently launched two new Airless® pumps for the growing Airless® market. The AZUR™ 52C225 and 72C160 Airless pumps are for protective coatings. They transfer material without compromising finish quality whether you are using single component paints, pre-mixed 2K, zinc-rich materials, or other types of coatings.

The SFLOW™ 275 & 470 manual Airless® paint sprayers are for applying protective coatings and are avail-

able in 275 and 470 bar (4000 & 6820 psi) pressures. These guns deliver real product savings for industrial applications. The ergonomic design offers flexibility in extreme conditions and is ideal for handling high solid content paints and high rich zinc primers.

In December 2020 we launched our FStart manual spray guns. The FStart G Gravity Airspray gun is an entry level spray gun that's easy to use and guarantees a high-quality finish. The FStart P spray gun is for spraying low to medium viscosity materials while ensuring a quality finish. And the FStart S suction-fed conventional spray gun is for hard-to-atomize coatings.

At SAMES KREMLIN, we do everything with our customers in mind, pursuing objectives of performance, productivity and sustainability. With our manual spray guns, automatic and robotic applicators, our wide range of pumps and machines for fluid handling, dosing, mixing, and dispensing, we allow you to "apply your skills" for the best performance and productivity possible

We are passionate about making manufacturers more competitive with a wide range of products, solutions, and services while delivering enhanced performance. With offices in Canada, the U.S. and Mexico, SAMES KREMLIN will provide innovation with an efficient supply chain to deliver the right solution to the right place at the right time, with a focus on customer satisfaction.

www.sames-kremlin.com



COMPLETE INTEGRATED SOLUTIONS

We manufacture state-of-the-art, high efficiency application equipment for applying paint, powder, and high viscosity products in the automotive and industrial markets.

- ROTARY ELECTROSTATIC BELL ATOMIZERS
- FLUID DISPENSE & MIXING SYSTEMS
- AUTOMATIC & MANUAL PAINT SPRAY GUNS
- TURNKEY GENERAL INDUSTRIAL SYSTEMS



800.573.5554 | VISIT US @ sames-kremlin.com

PLETHORA OF CHOICE AND INNOVATION IN MANUAL SPRAY GUNS ARENA



SAMES KREMLIN FStart G.

Despite ongoing interest in automation, manual spraying still remains a very effective method for painting. Providing the system is chosen appropriately, spray guns are set properly, and operators use proven techniques, clients can benefit greatly.

Whether the application involves large-scale industrial finishing or delicate precision painting, a spray gun is the key component in any finishing system. The right tool for the application is a combination of several factors including the delivery system and atomization method, as well as the spray gun's air cap, fluid tip and needle combinations, says ECE Canada, which distributes the pioneering names of Binks and DeVilbiss spray guns, among others. The best tool for the job will allow the operator to maximize the finish quality in a minimum amount of time.

In the **DeVilbiss Tekna** line, the ProLite Pressure Feed gun features high transfer efficiency for increased material savings, uniform spray pattern for optimum metallic control, and non-stick properties for fast clean up. The spray gun is also fully coated inside and out for corrosion resistance and protection from scratches. The line can be used with waterborne or solventborne coating in a variety of applications including aerospace, leather, wood, or metal.

SATA says its SATAjet 1000 K is "the all-rounder among paint spray guns". It is compact and lightweight, with material supply from pressure tanks or via double diaphragm pumps. A wide range of nozzles allow a wide variety of materials such as low-viscosity wood stains, clear lacquers, textured lacquers and glazes as well as adhesives and other high-viscosity materials to be painted.

Other features include ergonomic control elements such as ma-

terial flow control, a thumb-adjustable round/flat spray control and integrated air micrometer; quick air nozzle change with 1.5 turns; air guides on the horns of the air cap to prevent deposits caused by rear fog; and extensions in various designs so even hard-to-reach areas can be coated.

For more demanding areas of work such as body shops, **SATA** touts its SATAjet X 5500, its latest paint spray gun, which was developed in co-operation with Porsche Design Studio. Calling its X nozzle system "efficient, silent and consistent", the company says painters are able to cope with all paint systems and application recommendations. A "whispering" nozzle reduces paint volume and "gives a softer, more pleasant painting feeling" with reduced material consumption.

Painters can choose between the HVLP and RP technology, and between two different spray fan shapes for each nozzle size. The SATAjet X 5500 is also available with or without an integrated pressure gauge.

SAMES KREMLIN supplies all types of spray paint guns, accessories and tools. All body and aircap/nozzles are manufactured in Paris. The company says it focuses on achieving an ergonomic gun body design to ease both painting working conditions and the atomization quality for a quality finish and transfer efficiency.

The company's newest launch, in December 2020, was the FStart manual spray gun line. The FStart G Gravity Airspray gun is an entry level spray gun that's easy to use and guarantees a high-quality finish of materials such as stains and topcoats. (The FStart P spray gun is for spraying low to medium viscosity materials, while ensuring a quality finish. And the FStart S suction-fed conventional spray gun is for hard-to-atomize coatings.)



Above Centre: DeVilbiss Tekna Pressure Feed.

The development of spray gun technology has continued to this day and for the vast majority of industrial finishing jobs, spray guns are essential.



SATAjet 1000 K.

Other manual offerings include the Airspray line (pneumatic range). These are low pressure, HVLP gravity spray guns with cups. A full range of aircaps and nozzles create the desired perfect fan width for any part to be coated. The FPro and FPro Lock “offer superior finishing for all levels of painters”.

SAMES KREMLIN describes the Airmix range as a medium fluid pressure spraying technology, somewhere between its Airspray and high pressure Airless lines. The company says the Xcite and Xcite Light spray guns “give incredible results, with limited overspray, high transfer efficiency and are particularly adapted to spray coatings in every wood industry projects. Our Xcite guns can be considered as HVLP paint sprayers when fitted with the right nozzle/tip.”



Nordson’s Trilogi AAA (Air Assist Airless) gun.

Airless paint spray guns are ideal for painting large surface such as with building and industrial applications.

Nordson’s range of manual electrostatic spray guns is “affordable, robust, lightweight, easy-to-use and deliver high transfer efficiency for the perfect paint finish”.

The Trilogi AAA (Air Assist Airless) gun can be used for a variety of liquid coating applications. The company says special injector technology achieves excellent atomization and is available with an extensive range of round or flat nozzles for versatility in any painting operation. The line also features external adjustable needle seating and rear paint needle removal for easy maintenance and low trigger force to reduce fatigue.

The spray gun has a lot of history, being invented even before the automobile, a now-ubiquitous market for the tool. In the late 1800s, Dr. Allen DeVilbiss was looking for an easier way to apply medicine to his patients’ throat and nasal passages. He invented the DeVilbiss atomizer to fulfill this need. Soon afterwards, the atomizer was adapted to industrial use and spray equipment was born.

The development of spray gun technology has continued to this day and for the vast majority of industrial finishing jobs, spray guns are essential. The choices are then astounding in terms of the best option for your shop. ■

Gema: The Global Leader in Powder Coating Technology

When you want to know that everything is covered, Gema automated powder coating systems offer you greater efficiencies while producing consistent high-quality results. We provide the very best in powder delivery, application technology, and connectivity for smarter factory automation. Gema leads the way in optimum performance, repeatable process control results and color change solutions by offering the latest product innovations designed to maximize productivity and color change flexibility.

Managing your overall powder coating process is easier with our MagicControl 4.0 Data Management System, by putting synchronized monitoring and complete control of your entire automated process at your fingertips. Our MagicControl 4.0 is the most powerful and user-friendly platform in the coating industry for complete Smart Factory Automation. Line Management visualizes your coating system on screen to provide deeper insight into your line's utilization and efficiency. Energy Management allows you to monitor energy and compressed air consumption, make daily optimizations, and savings. Batch Management offers tracking of consumed powder divided into production batches. Sequential Programming allows serial coating of complex components by enabling individual movement sequences.

Gema has a unique solution for total optimization of your automated powder coating process. Our OptiStar All-in-One® Powder Control Unit is the first ever to combine electrostatics, injector pump control, and powder delivery all in a space-saving footprint while providing optimal coating efficiency. Our OptiCenter® OC06 Powder Management System, with the OptiStar All-in-One mounted directly on its hopper, improves powder delivery time to your spray guns. Our fully integrated system allows for delay-free cloud control to reduce powder consumption, fast and efficient color changes, easy maintenance for cleaner operations, and consistent top-quality coating results all controlled by a smart and user-friendly interface.

Gema's product offerings include manual and automatic spray guns and booths, fast color change equipment, cartridge and cyclone recovery systems, gun movers, control systems and other ancillary equipment.

Gema North America offers direct sales and distribution support in Canada, the United States and Mexico. To learn more or for further consultation, visit www.gemapowdercoating.com, email Powdersales@gema.us.com or call **800-628-0601**.



**VISUALIZE IT
AUTOMATE IT
MEASURE IT
TRACK IT
CONNECT IT
CONTROL IT
COMPLETE IT
SYNCHRONIZE IT**

Managing your powder coating process is easier than ever with the **MagicControl 4.0 Data Management System from Gema**. We have put synchronized monitoring and complete control of your entire automated process at your fingertips.

Line Management | Energy Management | Batch Management | Sequential Programming

Our MagicControl 4.0 is the most powerful and user-friendly platform in the coating industry for complete Smart Factory Automation. Make Gema a part of your shop and experience how simple it is to be so productive. **Complete it with Gema.**

Contact us for an evaluation.
877.437.6771 completeitwithgema.com



IN PURSUIT OF THE BEST FINISH



Wagner Cup gun PEM-X1 CG in action.



With the global powder coatings equipment market valued at US \$1.14 billion and growing, there is huge money to be made for equipment-makers, and dollars to be spent for end users in pursuit of the best finish.

Powder coatings equipment is projected to witness continuing significant demand as its high transfer efficiency, reliability and ease of use make it a practical coating method, says Grand View Research. Increasing usage in various applications including automotive, architecture, home appliances, and furniture will increase industry expansion over the upcoming years.

Manufacturers are continuously investing in the development of lightweight, compact, flexible, and easy-to-clean powder coating spray equipment to address issues such as space constraints and flexibility of coating complex shapes.

Gema's newest product, for example, is the OptiStar All-In-One unit.

"This product is a technological breakthrough in our industry as it combines the electrostatics and powder delivery into one compact unit," says Jeff Hale, Director of Marketing.

The company says it is the first control unit in the powder coating industry to combine electrostatics and powder delivery in a very compact device. The design enables important space saving system integration into Gema's OptiCenter powder management center. Direct integration of the powder injector into the OptiStar control unit eliminates the need for pneumatic lines between the injector and the control system. This results in a constant powder flow.

Gema says delay-free and exact control of the powder cloud is achieved by short reaction times to powder quantity adjustments. The rapid switching on/off of the powder feed also

reduces powder consumption. The OptiFlow powder injector is horizontally integrated directly into the OptiStar All-in-One control. This control unit also allows space-saving integration into the powder hopper.

"Another product that has a lot of attention is our MagicControl 4.0 operating system," says Hale. The MagicControl is used to control automated systems and offers smart factory data, he adds.

With the new generation of MagicControl system, Gema says, the coating process becomes even more manageable, through simple control of all aspects of the application, axes and entire coating booth system.



Gema's OptiStar All-In-One unit.

The control system operates as an interface for the automation of the powder coating process and enables intelligent networking of all application components. As a result, the production process is optimized and the line management efficiency can be maximized with relevant operating data retrievable at any time. All system components, warnings and error messages as well as storage of application programs are controlled by touchscreen. Parameter settings can be individually adapted to different powder types resulting in constant consistency and improved surface quality combined with minimal powder consumption.

Hale says more new products are coming this year, though he cannot comment on those at this time.

Nordson offers a complete line of spray systems to dispense powder coatings, including dense-phase and tribomatic technologies.

Its new Dynamic Contouring Movers (DCM) System, combined with HDLV technology, increases the automatic coverage of complex forms and achieves process control in the powder coating application, the company says.

“The DCM system automatically detects the product geometry and delivers superior coating performance by adjusting the position of each spray gun – and all this without any programming,” Nordson says.

Product geometries are scanned, with accuracy detecting protrusions larger than 5 mm at a line speed of up to 5 m/min, the company says. The information is then processed by the PowderPilot HD system controller and sent to the DCM.

“The system has a positioning speed of up to 500 mm/sec and accuracy of ± 1 mm to bring the soft spray to the optimum distance of the target product surfaces,” Nordson says. “The result is superior coverage of complex shapes.”

Wagner says its equipment enables optimal coating results on all types of surfaces. It touts its manual systems as very simple to operate, and automatic systems as high efficiency.

The Wagner Cup gun PEM-X1 CG is a manual cup powder gun that the company says is suited to laboratory and development purposes, as well as for powder coating of single parts and small quantities.

In the case of automatic systems, small batches or individual workpieces often have to be coated in different colors at the end of a shift, Wagner says. “The common practice is to do this in a spray-to-waste operation using the existing components including powder center, guns and powder hoses in order to keep cleaning and time expenditure due to color change as low as possible.

“With the PEM-X1 cup gun, coat small batches without the use of cleaning and time-consuming system components. All you need is the extraction capacity of the booth, which continues to operate in a spray-to-waste mode.”

The gun can be extended with a one-liter powder cup, which is equipped with a special valve to ensure proper powder flow. This also allows coaters to do individual workpieces as well as smaller batches without refilling powder. Any remaining powder can be



Nordson Encore.

stored in the extension cups for later use. A color change of the gun takes 20 seconds, Wagner adds.

Wagner also offers its Tribo and Corona lines of automatic powder guns for a range of applications where each gun can be tuned to the particular application and powder.

Gema's Hale says despite the pandemic, customers are continuing to explore and move forward with capital equipment purchases.

“Certainly the methods that companies are choosing to employ for meetings and demonstrations are different, however, I think everyone is adapting and getting more comfortable with the various methods in order to have productive meetings.”

To facilitate this, Gema is conducting virtual trials from its Swiss lab to engage with customers who are not able to visit the company's facility, but who are still seeking a demonstration of their product being coated. Hales says this usually involves video-conferences from a lab conference room as well as streaming live video of the product being coated.

“Customers may also choose to send key individuals to view the test in person and then have others join throughout the day for remote involvement,” Hale says. “While in-person meetings and demonstrations will always be preferred, virtual meetings and demonstrations are an alternate choice for companies to learn and experience our products, services and capabilities.”

Nordson says while the scientific principles and technology behind state-of-the-art powder coating are complex, it strives to make application easy. “We believe that with just the squeeze of a trigger, you should be able to unleash the power of a perfectly balanced system and get expert results.”

With everyone working together in new ways to achieve that best finish, it results in purchases all the way down the supply chain. Gema's Hale says the company is gratified.

“We are very appreciative of all businesses that are choosing to be progressive and work toward gaining a competitive advantage by investing in new capital equipment,” he states. ■



Above Centre: Gema OptiStar-All-in-One.

Introduction of Antimicrobial Wood Coatings

At Katilac Coatings, we pride ourselves on innovation. We offer a breadth of products to suit virtually all wood coatings applications. We have a comprehensive line of pre- and post-catalyzed lacquers, conversion varnishes, waterborne coatings and colour systems. At the forefront of KCI's new product introductions is an antimicrobial enhanced line of wood coatings, KCI-AMA™. These superior wood finishing products are designed, manufactured and certified exclusively in Canada. In addition to achieving the highest performance ratings, these products meet all the latest Health, Safety and Environmental Standards found across North America.

Conveniently, all KCI topcoats can be supplied with this built-in enhancement. This is a factory-built solution that is available ready-to-go. The standard performance characteristics of each topcoat remain unchanged when enhanced as a KCI-AMA™ solution. All KCI-AMA™ topcoats provide long term, dry film protection against a wide range of bacteria, mold, and fungus. They are non-leaching, non-toxic and certified for use in both Canada and the United States. Applied at the proper dry film thickness KCI-AMA™ dosed topcoats result in an antibacterial surface that provides long term protection against a wide range of pathogens including disease causing germs and viruses.

KCI-AMA™ enhanced coatings are available in waterborne, formaldehyde free, HAPs free, low VOC, as well as traditional solvent borne. Ideal for use in kitchens, schools, hospitals, restaurants, and senior care facilities. KCI-AMA™ coatings offers an unsurpassed level of durability for premium cabinetry, millwork, furniture, doors and windows.

Proudly Engineered & Manufactured in Canada

Our professional wood coatings are based on industry leading chemistry using the highest quality raw materials. With 40 years of experience in formulating, Dr. Richard Johnston and his staff of chemists are capable of handling even the most specialized client request for wood coatings. All products are manufactured and thoroughly tested at our production facility in Burlington, Ontario, that has been manufacturing wood coatings since 1962.

Distribution Centers

Katilac Coatings has a network of highly skilled distributors across Canada and into the US, which includes two company owned locations. All of our locations offer high quality custom colour matches, a full assortment of KCI products, as well as technical and application support.

Our Locations:

Katilac Coatings Inc.
391 Hanlan Road, Unit 1
Woodbridge ON
t. 905-856-6464
info@katilaccoatings.com

Katilac Coatings Inc.
840 Appleby Line
Burlington ON
t. 905-637-2931
orders@katilaccoatings.com



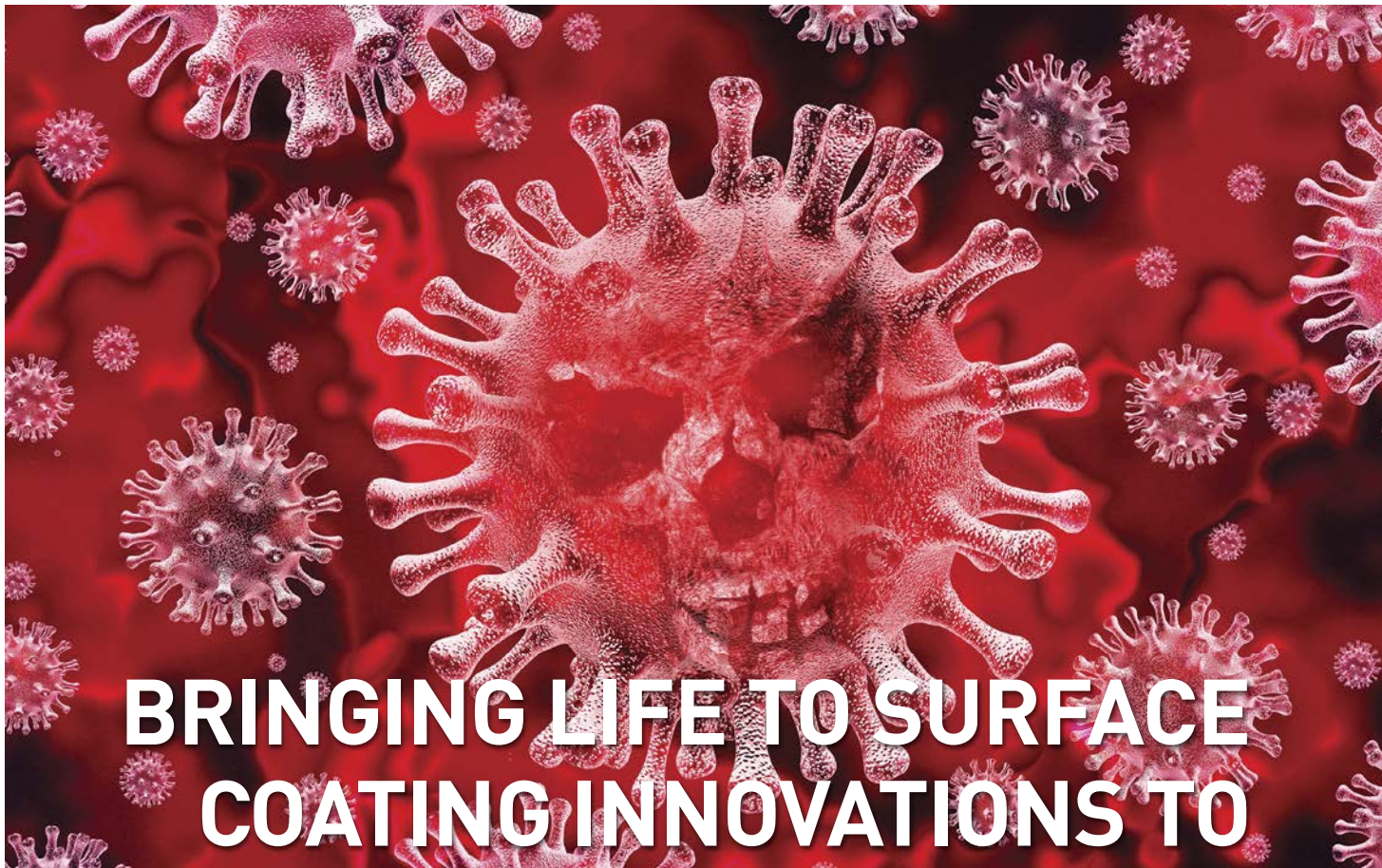

BRINGING LIFE TO SURFACE COATING INNOVATIONS TO KILL UNWANTED BUGS

In a short amount of time, the COVID-19 pandemic has changed life as we know it. The way we live, work, shop, travel, play, and more will never be quite the same. We've seen empty shelves for hand sanitizers and disinfecting wipes, as well as rationing. These products are no longer just for germaphobes; they're wanted by a majority. There is so much demand, stores cannot keep stock and many companies have stepped up to shift manufacturing to increase product availability.

Scientists have warned that coronavirus transfers both through the air and via surfaces, though there has been some debate about which surfaces and how long it survives. Nonetheless, a surface phobia – of doorknobs, handrails, playground equipment, and other objects like shopping carts – has created demand for industrial-type cleaning products and built-in virus killers alike.

Antimicrobial coatings are in the spotlight. However, surfaces treated with these coatings are not necessarily antiviral and effective against the COVID-19 virus, says Lux Research. Antimicrobial coatings inhibit microorganisms, while antiviral coatings are agents that kill viruses or suppress their ability to multiply and spread.

"Metallic antimicrobial agents like silver and copper have been shown to be effective against both bacteria and viruses, as they release ions that damage cell membranes, inactivate proteins, and degrade DNA, resulting in the cell's death," Lux says. "Other solutions like photocatalytic coatings have also been shown to be effective against bacteria and viruses."

It's a billion-dollar industry, with North America being the largest regional market for antimicrobial coating products at 35 percent of the market, according to a report by Grand View Research.

In our May/June 2020 issue, we reported on Guelph, ON-based EnvisionSQ which had developed a self-sterilizing nano-coating called NanoCleanSQ, with the University of Guelph. The product has since been renamed GermStopSQ.

It uses nanotechnology to bond to any material. The coating can be applied onto hard surfaces like handrails and hospital equipment or soft surfaces like fabric seats.

It can also be used on high-touch surfaces such as plastic chairs and doorknobs to reduce the spread of COVID-19, says University of Guelph engineering professor Bill Van Heyst, who helped develop the technology.

"There is tremendous opportunity for the application of NanoCleanSQ in hospitals, long-term care facilities, day cares, public transit and other public spaces where transmission of SARS-CoV-2 has been more prominent. It will have a direct impact on helping protect front-line workers and expedite the return to normalcy."

In most settings, one application is all that is needed, EnvisionSQ says. "Our semi-permanent coating can withstand exposure to moisture and will continue working whether the surface is wet or dry. Indoors, it will continue standing guard against pathogens week after week and month after month unless it is intentionally removed

How it works

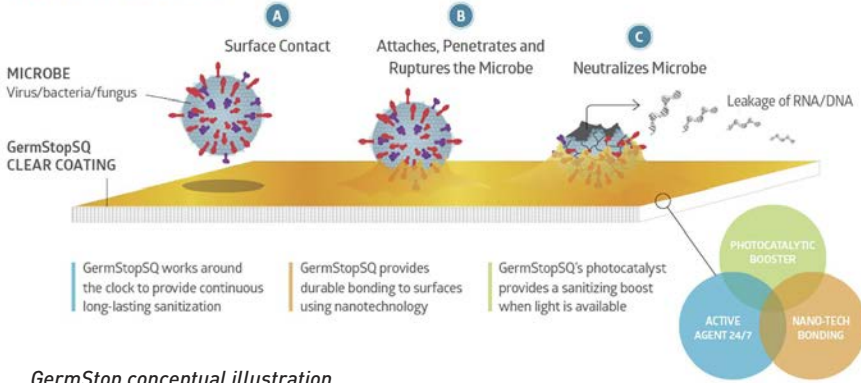

GermStop conceptual illustration.

with vigorous scrubbing. Outdoors, just apply a new coat after steady rain or snow.”

Though it’s an area of the industry that has existed for a while, it’s now a burgeoning one with a worldwide pandemic that still shows no signs of abating. Companies across the industry are developing products. Some are finding new ways to meet all of the demand.

PPG already offered antibacterial-protected powder coatings for protection across a wide range of applications but says it has increased manufacturing capacity. The turnaround for U.S. customers is 48 hours.

The company says its SilverSan technology “utilizes non-migratory, long-term antibacterial efficacy developed in the manufacturing process where silver ions are slowly released by way of an ion exchange mechanism.” Protection from microbial growth remains constant, even if the surface has been subjected to wear and exterior exposure, it adds.

SilverSan coatings can be formulated in many colors and resin chemistries.

Similarly, Axalta’s antimicrobial powder coating and additive offerings use silver.

Alesta AM is a powder coating solution treated with silver ion or silver zeolite technology that inhibits the growth of microbes on powder coated surfaces. These coatings provide corrosion protection to high traffic areas, such as healthcare environments, public transit and playgrounds.

Alesta RALGuard HAA is an antimicrobial additive designed to inhibit the growth and transmission of harmful microbes on powder coated surfaces. Axalta says add five percent RALGuard HAA additive to any Alesta RAL HAA powder coating to incorporate antimicrobial properties.

Turkish company, Kubilay, which makes wood painting systems, says its Ultra Hygiene

Series is the “world’s first and only antiviral wood coating”.

Kubilay says its products are effective against coronavirus “and provide full protection against viruses and bacteria in every corner of life where wood is used.”

Sherwin Williams says its Paint Shield microbiocidal paint is the first EPA-registered paint that kills greater than 99.9 percent of Staph (Staphylococcus aureus), MRSA, E. coli, VRE, and Enterobacter aerogenes within two hours of exposure on a painted surface.

“By killing these harmful bacteria, Paint Shield offers customers an important new tool to help prevent the spread of bacteria on painted surfaces,” the company says.

It says that once applied, Paint Shield is effective for up to four years, as long as the integrity of the surface is maintained, Sherwin Williams says. The paint can be applied on interior hard, nonporous ceilings, walls, doors, and trim.

Microban, which formulates additives and works with manufacturers to develop antimicrobial technologies, says its portfolio of antimicrobial technologies can be applied to thermoplastic, thermosetting, and other cross-linked or cured paints and coatings products.

“Delivery approaches, such as the use of granular, powdered, and liquid masterbatches, can be tuned to allow seamless incorporation into your manufacturing process without causing discoloration or affecting the final finish of the paint,” Microban says.

Its antimicrobial treatments are custom-formulated to fit a manufacturer’s specific application and criteria. Microban offers silver, zinc, antifungal and odor-control technologies.

“Microban technologies are implemented by decorative, industrial, and speciality paint and coating manufacturers across the globe, for a variety of different applications,” the company says. “Antimicrobial treatments for coatings also offer excellent in-can preservation properties.”

COVID-19 and other types of deadly viruses are not going away and therefore neither is the demand for antimicrobial coatings, additives and materials. Further research will be needed in terms of safety and cost (not even touched in this short article) but certainly these products will witness a historical revolution as consumer awareness and demand spark further opportunities for innovation. ■



DeFelsko Corporation, a leading U.S. manufacturer of inspection instruments, offers a variety of instruments to meet the coating industry's needs. Below is a summary of the new additions to the PosiTector and PosiTest line of inspection instruments.

Introducing the NEW PosiTector Gage Body

For nearly 40 years and five generations, the PosiTector platform has been a pioneer in the coatings inspection industry. Featuring the award-winning probe interchangeability that set the previous model apart, the new gage body is backwards compatible with nearly every PosiTector probe manufactured since 2012 including coating thickness, surface profile, environmental, salt contamination, and ultrasonic wall thickness. The new PosiTector gage body builds on this legacy with many industry leading features including a larger 2.8" impact resistant color touchscreen with redesigned keypad for quick menu navigation with or without gloves, new ergonomic design with a durable rubberized grip for comfortable all-day inspection, an updated modern user-interface, and on-gage help to explain menu items at the touch of a button.

The new weatherproof, dustproof, and water-resistant—IP65-rated enclosure and shock-absorbing rubber holster are ideal for the toughest environmental conditions including an unexpected rainstorm.

For more information:
www.defelsko.com/positector-gage-body

PosiTector DPM L Dew Point Meter Logger

The new PosiTector DPM L Dew Point Meter Logger makes it easy for inspectors to track and record environmental conditions on the job site. It magnetically attaches to steel structures to autonomously measure and record relative humidity, air temperature, surface temperature, dew point temperature, and the difference between the dew point and surface temperatures. Using a single battery, it can record readings at user-selected time intervals for up to 200 days. Stored datasets can be viewed or downloaded wirelessly via Bluetooth using a PosiTector Advanced gage body (S/N 784000+) or Apple/Android smart device.

PosiTest HHD High voltage Holiday Detector

The PosiTest HHD High voltage Holiday Detector offers unique features not commonly found in most holiday detectors. In addition to the built-in certified voltmeter,

the PosiTest HHD offers an optional hand-held wand accessory to convert the unit from a stick-type to a wand style detector — ideal for testing hard-to-reach areas. The American made PosiTest HHD uses pulse DC technology, offering a user-adjustable voltage range from 0.5 to 35kV for detecting holidays, pinholes and other discontinuities in coatings up to 20 mm (780 mils) thick. Use with a wide range of DeFelsko or competitive brush and spring electrodes.

For more information:
 Tel: 1-800-448-3835 (USA & Canada)
 (315) 393-4450
 Email: techsale@defelsko.com
 Web: www.defelsko.com

DeFelsko Corporation
 800 Proctor Avenue
 Ogdensburg, New York 13669 USA

PosiTest[®] AT Series
Pull-Off Adhesion Testers

Measure the adhesion of coatings to metal, wood, concrete and more

NEW AT-A Automatic Features...

- Impact and scratch resistant color *Touch Screen* display with keypad
- Wirelessly connect the PosiTest AT-A to your smart device using our free app
- Record the results as pass/fail and the nature of fracture — cohesive, adhesive and glue failures

AT-A Automatic model

Available on the App Store

Made in U.S.A.

DeFelsko[®]
 The Measure of Quality

DeFelsko Corporation • Ogdensburg, New York
 +1 (315) 393-4450 • techsale@defelsko.com
 1-800-448-3835 www.defelsko.com

MANAGING BY MEASURING

In the world of coatings, inspection and verification is required at every stage to ensure everything is to spec. From the preparation of the surface to be coated, through climatic condition monitoring to the dry film thickness evaluation, visual assessment and gauge-based testing will ensure process control and maximum results. After all, you can't manage what you can't measure.

One essential piece of equipment might be a spectrophotometer.

In January, Datacolor launched its Spectro 1000/700 series, which it calls "a family of close-tolerance benchtop spectrophotometers designed for high efficiency and confidence in color formulation and quality control".

The new series can be used to ensure uniform color assessments across various instruments and multiple locations throughout the supply chain. The system is designed to increase productivity and improve workflow through high measurement speeds and backward capability with other Datacolor benchtop instruments, the company says.

"Heightened by the pandemic and remote working trends, the need for digital exchange of color data has increased," says Albert Busch, President and CEO of Datacolor. "Datacolor set out to develop a family of high-efficiency spectrophotometers designed to meet the industry needs of today while also staying ahead of tomorrow's trends. Users can feel confident their instruments are ready to take advantage of future product enhancements, allowing for remote service and data analytics thanks to internet connectivity."

In addition, the Spectro 1000/700 series can capture the temperature of samples measured, "a game changer" with some materials that must be within a certain temperature range to ensure accurate color measurement, says Datacolor.

On the more affordable and portable side, the company offers its ColorReader Spectro which is a Bluetooth-connected device for those companies who might need to add a handheld device to their



Datacolor Spectro 1000.



DeFelsko KitCase.

existing lineup of color measurement instruments. A handheld device means added flexibility in measuring large, cumbersome samples that a traditional benchtop spectrophotometer is unable to handle.

DeFelsko also recently added some new additions to its PosiTector and PosiTest line of inspection instruments.

A new PosiTector gauge body includes a larger 2.8-inch, impact-



DeFelsko 6000.



Fischer MMS Inspection DFT.

resistant color touchscreen with redesigned keypad for quick menu navigation with or without gloves, a new ergonomic design with a rubberized grip, an updated user-interface, and on-gauge help to explain menu items.

The body is now weatherproof, dustproof and water-resistant and comes with a rubber holster for extra protection.

The PosiTest HHD High Voltage Holiday Detector offers some unique features not commonly found in other holiday detectors, DeFelsko says.

“In addition to the built-in certified voltmeter,” the company explains, “the PosiTest HHD offers an optional handheld wand accessory to convert the unit from a stick-type to a wand-style detector – ideal for testing hard-to-reach areas” while the pulse DC technology offers a user-adjustable voltage range from 0.5 to 35kV for detecting holidays, pinholes and other discontinuities in coatings up to 20 mm (780 mils) thick. The unit can be used with other DeFelsko or competitive brush and spring electrodes.

Fischer’s MMS Inspection line is its newest series.

“The MMS Inspection DFT is the all-rounder in the field of coating thickness measurement,” Fischer says. It can handle coating thickness measurement on both steel and non-ferrous metals and is protected against dust and water by an IP65-rated housing.

“Signaling through light, sound and vibration immediately indicates whether the readings are within tolerance – without having to look at the display of the coating thickness gauge,” the company adds.

A rotating display makes reading the measured values easy in any position. Up to 250,000 measured values in 2,500 batches can be stored and then transferred via USB.

In terms of benchtop units, Fischer’s Couloscope line works with any metallic layer and multi-layers can be measured on any substrate, the company says.

The Fischerscope MMS PC2 is an all-in-one system to measure coatings and test materials for both coating thickness measurement and material testing. The instrument can be customized via

eight plug-in modules and interchangeable probes.

For its part, Elcometer offers a host of inspection devices. Many of them are digital which makes readings quick, easily stored and recalled, and accurate. From steel surface preparation to coating thickness to post coating assessment of adhesion and porosity, the company offers a full range of detectors.

For the lab, Elcometer launched its 130 SSP Soluble Salt Profiler which measures the level and density of soluble salts on surfaces and can provide Bresle equivalent values.

“The multi-point measurement electrode not only provides four Bresle equivalent readings in just over two minutes – over four times faster than other Bresle equivalent test methods, but the user can also view a comprehensive salt distribution profile map – providing a more accurate indication of the amount of soluble salts on the test surface,” Elcometer says.

In the field, the Elcometer 500 Coating Thickness Gauge accurately measures the thickness of coatings on concrete and other similar substrates, non-destructively.

Fast and accurate, Elcometer says the 500 Coating Thickness Gauge takes repeatable and reproducible dry film thickness measurements of coatings on concrete up to 10mm thick – without damaging the coating.

Taking more than 60 readings per minute in standard mode and more than 140 readings per minute in scan mode, the 500 Coating Thickness Gauge allows users to inspect more coatings in less time. There is a choice of probes designed for continuous use and field-replaceable probe tips.

The built-in signal strength indicator prevents false or incorrect readings, as the gauge only displays the coating thickness measurement if the signal strength indicator goes green.

Whether looking at colors, layer thickness, material analysis or material testing, in the lab or in the field, testing device makers are constantly improving and expanding their product ranges. With such a range of offerings, shops should be able to easily measure and manage the coating requirements of every job. ■

Fischer Technology, Inc.

Check the physical properties and composition of surface treatments quickly, easily and non-destructively – without special sample preparation or problematic waste products Fischer has over 60 years of experience in the development of customized measuring instruments that are tailored exactly to the needs of specific industries. Need an individual solution for your measurement task? Just contact us!

Contact Us Today!
Fischer Technology, Inc.
 860.683.0781
sales@fischer-technology.com
www.fischer-technology.com



Automotive: The quality assurance of functional and decorative finishes in automotive construction calls for precision testing of coating thicknesses and material properties.



Chemicals, Petrochemicals, Mining: Robust and highly reliable solutions for metrological tasks throughout the chemicals and petrochemicals industries.



Electronics and Semiconductor Industry: Measurement technology for electronics such as printed circuit boards, surface-mounted components and semiconductors.



Galvanization, Anodization: Fixed or portable measurement devices for anodized or galvanized surfaces.



Hard Material Coatings, PVD, CVD, DLC: Accurately test the properties of innovative functional surfaces to ensure optimal performance.

Turn Key Quality Measurement Systems

Electroplating & Metal Finishing:

- Anodizing
- Gold purity & plating thickness
- Electroless Ni P% & thickness
- Electrolytic Ni
- SnPb & Sn electroplating
 - RoHS & HiRel

Contact us today!
 Fischer Technology Inc.
 860.683.0781
www.fischer-technology.com
info@fischer-technology.com



KEY INGREDIENTS FOR A BIOCIDES MANIFESTO

By Gary LeRoux

A biocide manifesto for the paint and coatings industry would essentially state that antimicrobial control is critical for product performance, brand reputation, sound regulatory alignment and socio-economic growth. The only way this can be achieved is with collaborative, evidenced-based decision making between industry and government on both sides of the Canada-United States border. Refusal to approve registrations for certain biocides, or decisions to hastily impose additional label rate restrictions has a long-term, negative effect on the number of highly performing, eco-friendly paint products that can be imported, manufactured and sold in Canada.

The Canadian paint industry continues to face complicated trade-offs between the “formulation-driven” trend toward higher preservative concentration levels needed in waterborne coatings due to recent VOC regulations, versus the “regulatory-driven” trend toward lowering paint preservative concentrations generally. It is a trend that will lead to unsafe thresholds for biocides used in coatings formulations leading to increased bans, restrictions and/or increased hazard communications related to risks of residential and occupational safety incidents.

A more focused and integrated approach is needed to reconcile these two divergent trends. This must be addressed on both sides of the border in biocide re-evaluations and related risk calculations. For example, dermal absorption values cannot be made without considering the dose of a substance that actually reaches systemic circulation following dermal uptake. Similarly, systemic absorption (bioavailability) after inhalation exposure cannot be determined without consideration of differences in regional deposition within the respiratory tract as a function of particle size. Failure to factor into the risk calculation the dose available for systemic exposure, while utilizing toxicological endpoints, distant from the site of exposure, increases the likelihood of unrealistically high exposure estimates, which then produce unusually high-risk calculations. That, in turn, will unnecessarily lead to more bans and use restrictions for biocides.

CPCA stresses the importance of a more efficient and better aligned North American review process for biocides to maintain fair trade in products and easy access to a sufficient number of biocides in both countries for paint manufacturing. This recognizes

the relevance of a highly integrated Canada-US economy and new efforts for increased cooperation under the recently signed free trade agreement, the USMCA. Over the past several months, large North American manufacturers also considered the evaluation of several active paint biocides assessed by the US-EPA. These included sodium pyrithione, ITAs (Isothiazolinones), carbendazim, folpet and DBNPA (Dinitrobenzotrile propionic acid). Under the recent PMRA “paint cluster analysis”, Canada addressed only two of the biocides in common with the recent US-EPA publications: sodium pyritone (or sodium omadine) and folpet. Although this common approach may be purely coincidental, CPCA views this as a very positive sign as both agencies will further synchronize re-evaluation processes and harmonize the timelines going forward.

The concurrent assessment of several paint-related biocides in Canada and the United States in 2020 raised a number of serious industry concerns. First and foremost, it limits industry’s ability to maintain the current, and already limited, array of biocides in both countries for paint preservation for dry film and in-can applications. Industry must have access to those biocides to sustain existing performance levels during paint manufacturing, transportation and storage, for all types of Architectural and Industrial paint formulations. CPCA believes that the US-EPA and the PMRA should consider lifecycle assessment (LCA) for all paint preservatives available in future evaluations and re-evaluations.

CPCA stresses the importance of a more efficient and better aligned North American review process for biocides to maintain fair trade in products and easy access to a sufficient number of biocides in both countries for paint manufacturing.

Regulatory authorities cannot continue to systematically ignore the negative economic impact of their evaluations, especially in the context of a very limited number of preservatives remaining in Canada for paint formulators.

The value of the LCA would not necessarily be on the biocide itself, but as it relates specifically to the function and role within a product system or formulation. By doing so, the LCA could capture the benefits that preservatives provide in the system versus just focusing on their footprint. It is an important overall consideration with respect to product stewardship generally. A lifecycle assessment would capture the environmental performance of various architectural coating preservative scenarios used to determine the environmental impacts and benefits that wet-state and dry-film preservatives provide in architectural coating systems. It would also provide necessary insight on how reducing, eliminating, or replacing certain preservatives can impact the coatings' overall sustainability profile. It can also reveal how substitutions can alter the efficacy of those products and thereby increase product losses, environmental wastes and, indeed, health issues.

While preservatives have been reported to cause both local and systemic effects, the use of these assumptions for risk calculations associated with systemic endpoints will require further consideration of the mechanics that govern substance transfer from the site of exposure to systemic circulation. This is especially critical in light of the fact that PMRA recently used critical systemic toxicological endpoints that were remote from the site of exposure such as thyroid effects, reproductive and developmental toxicity, rather than local toxicological endpoints in selecting points-of-departure (PODs) for risk calculations. This is a critical deviation from standard practice for biocide evaluation and overstates the risks by a significant margin.

Evaluation of biocides must accept the fact that: 1) exposure via dermal contact is a two-step process involving dermal uptake and transfer into systemic circulation; and 2) that systemic transfer following dermal uptake is in fact minimal. The dermal exposure values often assumed by Regulatory Authorities in their risk

re-evaluation account only for dermal uptake, but not the transfer into systemic circulation, considering when a system (not a local toxicological endpoint) is used to determine the POD for risk calculations. As such, it renders dermal adsorption values unnecessarily high. Hence, the extent of dermal exposure that is utilized in re-evaluations is then considered much too conservative and which would not be encountered in the real-world application of paint products containing the biocides being evaluated.

Some biocide chemistries may negatively impact critical paint properties including, but not limited to, color, tint strength, gloss, scrub, and stain resistance. Paint manufacturers are therefore reluctant to alter their preservative packages. The sophistication and uniqueness of paint and coatings formulations makes it difficult to select a preservative. The selection of a biocide is governed by a variety of factors, and it must be understood that "one biocide does not fit all". Use of an alternative, of a similar chemistry or very different chemistry, requires a significant investment of resources, both financial and personnel, to test a variety of paint properties that could be impacted by further restrictions. Of greater concern is the dry film preservative because replacement of a dry film biocide requires a minimum of three to five years of exterior exposure on a test fence or substrate in the region(s) in which the paint product will be sold.

Regulatory authorities must also integrate socio-economic studies into the re-evaluation process for biocides. Regulatory authorities cannot continue to systematically ignore the negative economic impact of their evaluations, especially in the context of a very limited number of preservatives remaining in Canada for paint formulators. Rather than further reducing current use rates and banning more preservatives through individual assessments, risk assessors must carefully examine health effects along with economic effects, possible alternatives, availability and function of biocides, etc. Then, jointly with industry, consider all options available for certain problematic types of formulations and related risks. This is typically done in the United States late in the evaluation process, and after the risk evaluation is completed. It can also be done concurrently with the risk evaluation. CPCA suggests a process be established to address such matters outside the formal re-evaluation process, which can be incorporated, when and as needed, for specific biocides. This is critical for alignment in a highly integrated value chain.

Canadian paint formulators should also be able to use non-PMRA registered biocides in paint mixtures that are destined for exports to countries where they have been risk assessed and are considered safe to use. The very rigid position currently taken by the PMRA is incomprehensible. It means that Canadian paint formulators cannot use certain biocides to treat paint articles for export only to the United States and throughout the world. This is another socio-economic aspect that must be examined closely in any future decision in Canada. ■

Gary LeRoux is President and CEO of the Canadian Paint and Coatings Association. www.canpaint.com

Venjakob – A custom-made solution for all finishing applications CLEANING / PRE-TREATMENT / COATING / DRYING / AUTOMATION

Efficient coating systems for just about any industrial coating application

Whatever it is you would like to coat, Venjakob coating machines are used in just about every industry sector around the world. In accordance with varying customer requirements, Venjakob and its US subsidiary Nutro, Inc., can offer you a whole host of system solutions for processing liquids, including adhesives or coating systems based on water, solvent, or UV. Effect, decorative, and functional coatings, among other things, are applied in accordance with your requirements.

Venjakob represents so much more than just coating technology

While entire coating lines are our core area of business, Venjakob has developed and implemented plenty of special solutions for applications beyond surface technology. Should you be in need of a special solution in substrate drying or parts handling, please feel free to get in touch with us.

State of the art technology to make your business future-proof

Experience over decades has made us an innovative and reliable partner. The modular system concept enables you to adapt your production process to changing market conditions. When it comes to planning new systems and processes, our industrial laboratory provides you with the opportunity to do trials in realistic production conditions.

Venjakob – Established family-run company with global network

Venjakob, with headquarters in Germany, was founded in 1963 and is under third-generation management. It comes with a further production site in the USA (Nutro Inc./ Strongsville-OH) and several sales and service points around the world. Our customers trust in our expert knowledge and fast available service support.

Get in contact with us. Our Canadian Team will be at your disposal!

Venjakob North America Inc.
130 Healey Rd Unit #18
L7E 5B3 Bolton, Canada
Tel: 905 951 9966
northamerica@venjakob.com
www.venjakob.com

Headquarters:
Venjakob Maschinenbau GmbH & Co. KG
Rheda-Wiedenbrück/Germany

Venjakob

Nutro

CLEANING ♦ PRE-TREATMENT ♦ COATING
♦ DRYING ♦ AUTOMATION

A CUSTOM-MADE SOLUTION FOR ALL FINISHING APPLICATIONS

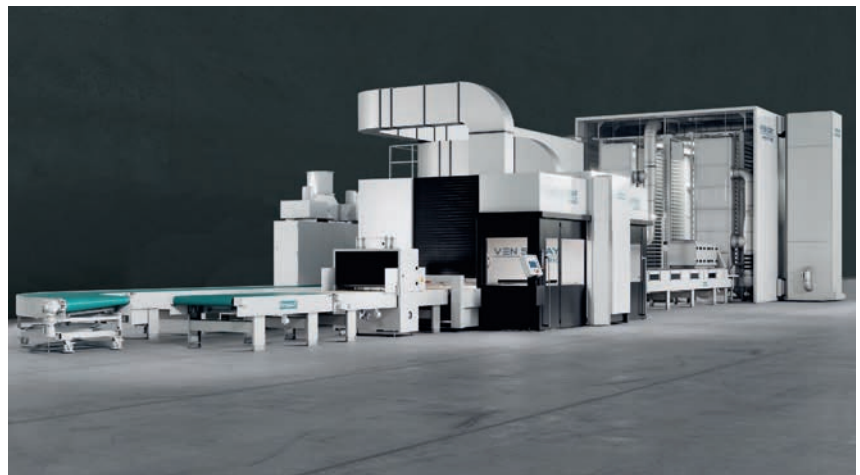

FOR
WOODEN
AND PLASTIC PARTS

FOR
VARIOUS
METAL PARTS

**Venjakob
North America Inc.**
130 Healey Road, Unit #18
Bolton, Ontario | L7E 5B3
Andrew Scott
ascott@venjakob.com
Phone: 905 951 9966
www.venjakob-na.com



Nutro Inc.
11515 Alameda Drive
Strongsville, OH 44149
Mark Rooney
mrooney@nutroinc.com
Phone: 440 572 3800 Ext: 139
www.nutroinc.com



CONTROLLING AIR EMISSIONS IN ANODIZING AND PLATING

Control of emissions into the air is an issue for a broad range of industries. However, metals finishing has a unique set of problems that need effective technologies to reduce their potential health hazards.

Metal ions themselves, along with the compounds formed from them, are constantly emitted into the work area, posing a potential threat to workers, and also to other businesses or homes close to the plant. Any anodizing or plating operation needs to ensure it does not incur expensive legal penalties or civil litigation through failing to protect its workers as well as its immediate neighborhood.

The best known, and perhaps the most studied, problem today is emissions from chrome plating. While hexavalent chrome, the most hazardous version of the metal, is being phased out of many applications in favor of trivalent chrome, complete elimination is not really possible.

Hexavalent chrome, or the chromic acid that is given off from plating processes, is both toxic on its own and a recognized carcinogen.

Chrome plating is a process whereby a thin layer of chromium is deposited electrochemically onto another metal that serves as the substrate. The process results in significant gassing from the process tank, with the gases rising to the surface as bubbles (more than 80 percent of the electrical energy used in plating produces is not the actual metal deposition, but the gas bubbles).

Most of these bubbles burst at the surface, forming aerosols (mist) that are then released to the atmosphere. These aerosols consist of the process liquid containing chromic acid, and without the use of a mist suppressing agent, the environment becomes contaminated.

There are various types of wetting agents and fume suppressants in use. Surface-active fume suppressants go directly into the chromium plating bath.

Some types produce a foam that helps suppress the mists produced on the surface of the bath, while wetting agents directly affect the surface tension in the bath to reduce the misting effect. Reducing the surface tension cuts the potency of the bursting of the bubbles, resulting in less misting. Mist suppressants are organic compounds with components have opposing solubility tendencies, typically an oil-soluble hydrocarbon group and a water-soluble ionic group.

Still, whatever measures are used to reduce the airborne emissions, some degree of emission still occurs. At this point, custom extraction systems and specialty air evacuation methods need to cut in, to ensure that safe levels of breathability are maintained throughout the manufacturing cycle.

Viron International Corp. has been producing scrubber systems since 1971. Its Viro Chrome 9000 Series was designed to meet the stringent California Hexavalent Emission requirements along with US federal emission standards. The system, Viron says, has exceeded these requirements of 0.006 mg/amp hour of chrome emissions.

The 9000 Series is available with the scrubber housings made in either PVC – (Type I, Class1) and fiber-reinforced plastic (FRP) modes. PVC is well established for its chemical resistance, and the FRP version is made from Hetron 197 or its equivalents.

Viron manufactures its scrubber housing utilizing a 10 to 20 mil veil liner followed by an 80 mil chopped corrosion liner. The housing is then covered with a structural layer of FRP and a UV inhibited gel coat.



A vertical scrubber from Mech-Chem.

The moisture eliminator uses a three-stage knitted type mesh pad made of polypropylene. This series of mesh pad type and configuration has been designed to meet the California regulation.

PVC spray nozzles are employed in each of the chrome scrubbers. These nozzles spray the mist eliminator pads to keep the chrome from building up and clogging the pads. The spray nozzles will be sized for a range of .25 to 1 gpm per square foot of mist eliminator pads.

All spray header pipes from Schedule 80 PVC pipe. Each spray header has a Schedule 80 true union, which facilitates removal and maintenance of the spray nozzles.

Mech-Chem Associates Inc. designs, fabricates and installs scrubbers for all types of chromium-using applications, in-

cluding anodizing, etching, plating, stripping, decorative plating, and hard chrome plating. It has fume control systems for use with chromic acid, trivalent chromium and hexavalent chromium, and it advocates a different approach than mist-type systems.

"A packed bed scrubber with a Chevron mist eliminator will have a moderate chrome removal rate," the company states. "Using a mesh pad instead of a mist eliminator will increase the amount of chemical laden droplets kept from exiting the scrubber, yet neither of these designs offer the high efficiency removal rate required by today's air emission standards."

The majority of scrubbers, the company points out, function using adsorption, which involves the contact of a gas stream with an aqueous solution. However, due to the fact that the chromium exists in the mist droplets, and not as a gas, the adsorption method is not entirely effective.

"To properly scrub chrome," Mech-Chem states, "mesh pads are used to create separation of the chrome-laden vapor from the air stream on contact. By using these mesh pads in a multi staged set-up, within a horizontal scrubber, chrome scrubbing efficiency greater than 99 percent can be achieved."

The mesh pads are considered key in chromium scrubbing due to their high removal rates of the metal, ability to handle moisture build up, resistance to being plugged, reduction of pressure drop through the scrubber and their ability to handle larger volumes of air laden with chromium-contaminated liquid. These factors, the company says, reduce both operating cost and overall maintenance of the system.

Tri-Mer Corp.'s offering in this market is a mechanical one. Its Fan/Separator is an all-mechanical, two-stage fume scrubber that can be used for sulfuric acid pickling, metal plating, and battery charging operations. It therefore includes chromium fume control in its portfolio of applications.

The scrubbing liquid wets the contaminant as it enters the fan, allowing it to be centrifugally spun out of the fan scroll through dynamic mixing. The centrifugal action, using the fan wheel as part of the scrubbing process, eliminates a reported 55 percent of all airstream contaminants. The scrubber has dynamic scrubbing as its first stage and impingement as its second stage.

The impingement process causes the air to change direction as it passes across the rigid packing media. The packing media also act as a mist eliminator section.

It is supplied in framed packs and provides a claimed 99 percent removal efficiency of 20 micron and larger liquid droplets under a continuous duty load. Contaminants enter the eye of the fan where they are treated with a fog mist of scrubbing liquor.

The system is claimed to operate with 20 percent less brake horsepower than conventional fume eliminators. The fume scrubber's high efficiencies are possible, Tri-Mer says, due to its unique use of the fan as a centrifuge in the scrubbing process.

Fan velocity is precisely controlled so that air crossing the rigid packed media stays within design parameters. The system is positively pressured, working in a manner that is the reverse of conventional "negative air" scrubbers. Thus, air is pushed, rather than pulled, through the system.

Tri-Mer says 55 percent of the system's performance results from contact between the contaminant-laden air and the rigid tube packing, while 45 percent is from the centrifugal action of the fan wheel. The unit is said to be extremely effective in eliminating corrosive contaminants, and the outlet is near saturation. Total energy consumption is reportedly 15 to 20 percent less than comparable wet scrubbers with a negative pressure design.

The Tri-Mer fume scrubber was engineered for simple installation and start-up, so start-up costs are said to be low. Fan/Separator units are manufactured of PVC, polypropylene, stainless steel or mild steel. Tri-Mer will select the appropriate material for each application. The company also designs and manufactures duct systems in PVC, polypropylene and fiber-reinforced plastics.

All scrubbing systems need to be configured on a custom basis, with no two anodizing plants being alike. The accumulated knowledge that major suppliers now have from decades of experience might not guarantee a perfect solution, but the problems of emissions control are improved every year as the technology advances. ■

CHECK OUT

WWW. cfcfm.ca

The CFCM Website

Features:

News, Back Issues,
Buyers Guide,
Event Photos,
People,
New Products
for Finishing
and Coatings
Manufacturing.

Check it out Today
and Every Day!



Please send all your News,
New Products to Theresa Rogers
theresa.rogers@cfcfm.ca

For Advertising Please Contact
Gillian Thomas 1-416-277-1269
gillian.thomas@cfcfm.ca

 **CFCM**
CANADIAN FINISHING & COATINGS MANUFACTURING MAGAZINE

Service Filtration of Canada, Ltd.

Top Supplier in Canada for Filtration Equipment, Pumps, Heaters, and Liquid Transfer Systems

Service Filtration of Canada is a leading distributor of liquid handling equipment for chemical, surface finishing, and other wet process applications. Since its inception in 1988, Service Filtration of Canada has distributed remarkable equipment across the country and has gained its reputation by delivering high-quality and innovative products. We are specialists in the selection of corrosion-resistant pumps, filtration systems, filter media, heaters, and agitation systems. Our company continues to bring new products to the marketplace that enable chemical processors and surface finishers to improve quality, save money, lower maintenance time, increase safety, and protect the environment.

Our team carries over 75 years of combined technical and industry experience. We take great pride in all the equipment we introduce to the marketplace. Magnetically coupled pumps, vertical pumps, externally mounted single and double mechanical seal pumps, all plastic or metallic filtration systems, and pumped agitation systems using eductors to agitate process and cleaning solutions are some of the innovative solutions we have brought to our customers across Canada.

Over the last three decades we have seen many changes in the fields of Surface Treatment, Chemical Processing, and Chemical Manufacturing industries. As these changes were taking place, equipment was also changing. Newer and better

designs, along with a broader array of chemically resistant materials are being used to provide the tools needed to produce and process more effectively and efficiently, as well as providing greater safety for operators and the environment.

All chemicals need mixing, transferring, purifying, batching, and packaging in some way or another. The team at Service Filtration of Canada is here to help you make the best decisions so that your facility has the most technically advanced, cost effective, and environmentally friendly equipment available. Safety comes first, so all our equipment is designed and manufactured with the safety of users and your team members uppermost in our minds. Reliability, commitment to customer service, product availability, and technical knowledge are all at the heart of Service Filtration of Canada.

Our mission is to be a proactive partner with our customers in the vast array of industries we serve to meet the challenges imposed by a global economy and increasingly stringent governmental controls regarding safety and wastewater management.

We will always stay up to date with the latest technology. Our equipment can handle all liquid handling and wastewater treatment applications, with the aim to achieve product integrity, high-quality, and cost savings. Contact us today to get information about the industry leading equipment we offer at info@service-filtration.com or visit our website at www.service-filtration.com (new website coming soon).

SERVICE FILTRATION OF CANADA, LTD.

Global Products, Local Service, and Advice You Can Rely On



Service Filtration of Canada is a stocking distributor for industrial equipment such as: Pumps, Filtration Systems, Filtration Media, and Process Controls. Since 1988, we have been providing our customers with pumping solutions, filtering innovations, and superior product lines.

Pumps



- ✓ Improve Profitability
- ✓ Improve Quality

Filtration Chambers & Media



- ✓ Reduce Emissions
- ✓ Reduce Waste

Heaters



Systems & Controls



- ✓ Save Energy
- ✓ Low Maintenance

Passionate about our equipment for over 30 years

www.service-filtration.com

(800) 565-5278

info@service-filtration.com

THERMAL CONTROL IN METALS FINISHING

Temperature regulation is a field that is constantly developing, as ever-more precise systems with new and more advanced algorithms enter the market. It reached a certain plateau with the standardization of microprocessor-based units, but there is still room for improvement.

There are also the issues of cost and durability to watch for, even when the technology itself has proven it is viable. Measuring temperature extremes exposes instruments to harsh conditions, so they have to be designed and assembled in a way that will not fail after a short period of use.

Much of the thermal control equipment on the market is custom-made, rather than off-the-shelf. Plants in this field often tend to be designed ad hoc by their owners, starting very small and gradually adding components from various sources as the business builds. Titan Industrial Heating, which specializes in the area, and particularly in autocatalytic nickel plating (often called electroless nickel plating), stresses that it has no standard stock products that serve this industrial category. However, it can custom manufacture to users' exact requirements, and has extensive experience in nickel plating, which is performed in a heated tank.

"Correct process temperature and safety concerns in chemical plating tanks require constant temperature monitoring," Titan says. "This is often done with thermocouples of different dissimilar metals connected to a digital temperature controller. Maintaining correct temperature in metal finishing tank and limiting outside parameters like evaporation of solutions can be easily controlled by installing the thermocouple at correct location."

For example, if the tip of the sensor in a chemical process tank is located at the bottom of the tank, the control can not sense the "raising heat" and will consequently stay on to meet the demand of the control. It is therefore essential to be sure the sensor is located in the top 30 percent of the process solution.

"Thermocouples are cost effective and easy to exchange," the company points out. "In case of a thermocouple failure, the digital temperature controller will alarm."

Besides constant control of the temperature, Titan also recommends installing a liquid level safety control. This is a vital safety device in plastic tanks (those made of polypropylene, or PTFE coated) and also described as a good investment in metal tank because solutions evaporate, tanks fracture, erode, corrode or disintegrate due to electrolysis.

Titan's capabilities extend from small controls to heat a simple tank, up to those needed for a new shop with RS-485 integration with data collection. Such a system has the ability to notify the user by phone of the status of the system.

Today's higher demands on accurate process temperature controls in plating tanks, documentation and safety concerns, require the use of digital temperature controls, the company stresses.

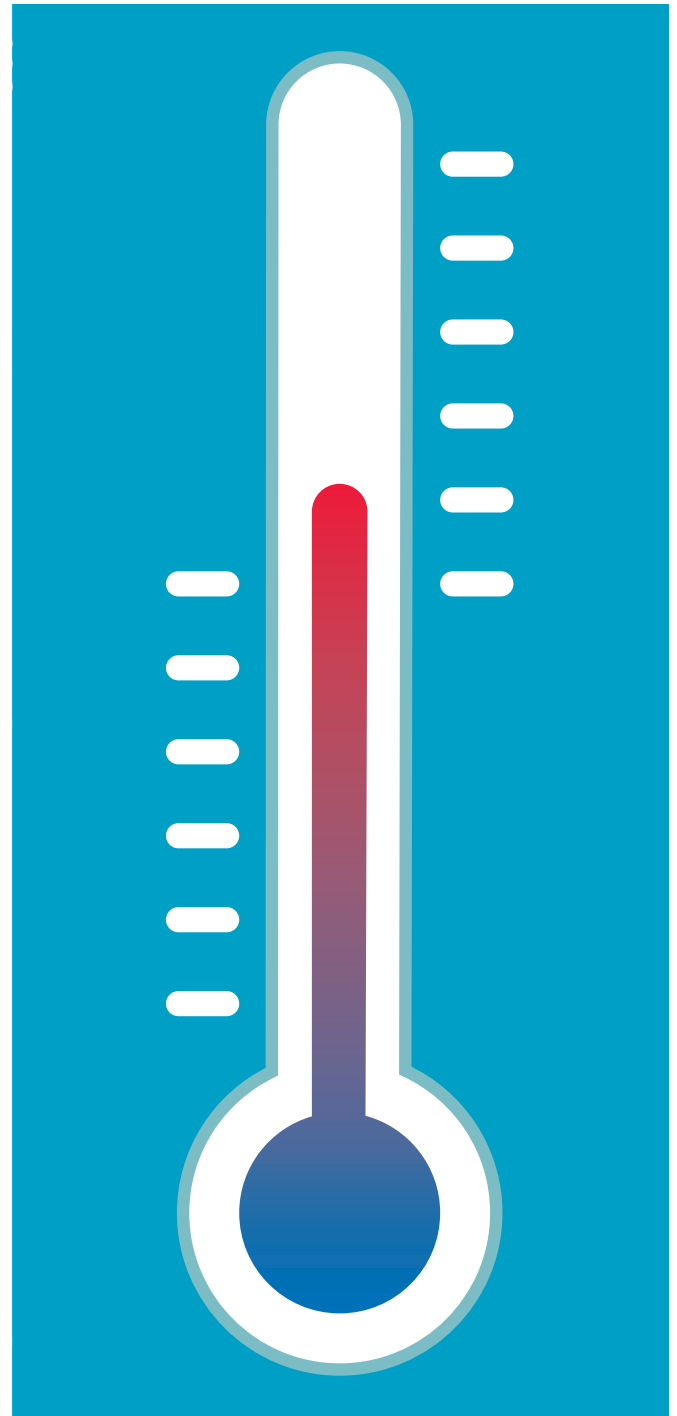

Metal finishing tanks with old-style gas-filled capillary assemblies for temperature control lack the accuracy (+/- 5 deg. F) and safety (they can fail in closed position) now required.

The temperature controller receives inputs from a temperature sensor or an RTD. The display of the digital temperature controller can be up to 100 ft away from the metal finishing tank, so if the controller is connected to a RS-485 communication system, operators can control, monitor and record the temperature settings from a remote location.

Safe operation of a plating or rinse tank necessitates the installation of a liquid level control. Integrating this safety device into the digital temperature control terminal box is, Titan explains, economical as well as improving operational safety. This additional safety device can also have an impact on insurance costs.

The most effective way of regulating anodizing temperature is by using an anodizing cooling system. Most oxidation plants use either a water-cooled chiller with a cooling tower or an air-cooled chiller to achieve an optimal anodizing temperature.

Cold Shot Chillers anodizing cooling systems include air-cooled and water-cooled chillers. In explaining its technologies, the company points out that “A significant amount of heat is generated during an anodizing session. Generated heat must be properly dissipated from the anodizing process to ensure even oxidation.

“The most effective way of regulating anodizing temperature is by using an anodizing cooling system. Most oxidation plants use either a water-cooled chiller with a cooling tower or an air-cooled chiller to achieve an optimal anodizing temperature.”

Cold Shot’s air-cooled and water-cooled chiller systems can be installed alongside the vessels containing the electrolytic fluid. A fluid refrigerant is circulated through a metal finishing chiller, which then circulates through a heat exchanger to cool the anodization process solution. The warmed refrigerant is sent back to the chiller to repeat the loop.

“Temperature changes within the anodizing vessel are detected by a thermal regulatory device installed inside it,” Cold Shot explains. “When there is an increase in the amount of heat being generated by the anodizing process, regulatory valves in the chiller system are opened either automatically or manually to allow coolant flow through the heat exchanger and cool the vessel. These valves are shut off when optimal temperature ranges have been restored to avoid overcooling the electrolytic process.”

An alternative method of regulating anodizing temperature is using cooling coils that are immersed directly into the anodizing

solution. Although this method is less costly to install, it has some drawbacks when compared to a standard anodizing cooling system that operates with an external heat exchange, and thermoregulation is less precisely controlled.

Cooling coils may leak, introducing refrigerant into the anodizing vessel causing contamination and disrupting the oxidation process. There is, the company says, a risk of electrolytic chemical corrosion of immersed cooling which will drive up operating costs.

Baker Technology Associates, which specializes in rack and barrel plating systems, is another supplier that makes energy-conserving designs its specialty. State-of-the-art controls are integral to this, the company says.

“By minimizing losses from heated tanks, and dramatically reducing exhaust cubic feet per minute – often by more than 80 per cent – we deliver significant savings in recurring heated make-up air and energy consumption, especially in northern US and Canada,” Baker states. “Integral to the system’s success is state-of-the-art controls. For more than 20 years, we have exclusively utilized AUCOS control systems.”

All its control systems offer production scheduling, advanced real-time simulation, verification of layout and capacities, and optimized concurrent processing of widely varying process recipes and dwell times. Additionally, unlike some scheduling systems, there is no need for part or fixture storage, or a queue. The controls are available in UNIX, LINUX and Windows platforms.

Baker Technology Associates Inc. has its patented Platexpress System. This, the company says, provides a more consistent finish with lower operating costs. It also offers a separate hybrid system that uses many of the Platexpress features, but with a traditional barrel/hoist orientation.

The main Platexpress system features lowered electrical power consumption and thus reduced energy heating costs. It also features lower solution drag-out.

“Water consumption and floorspace requirements are reduced by up to 50 percent,” Baker states. “It also reduces maintenance costs, and lowers both exhaust emissions and the recurring cost of make-up air.

Baker additionally offers in-barrel drying. Unlike conventional, centrifugal drying, the company states, the more delicate parts need not be dumped into spin baskets for placement inside the dryers.

Following a final online rinse, the barrel is conveyed to semi-vacuum dryer stations featuring special, minimal rotational cycles. Baker adds that the barrel dryers are available with automatic covers, to minimize energy losses.

In most instances, industrial temperature control systems use well-tried methods that have been around for decades. However, as the need for precision grows in today’s markets, reinforced by some customers’ requests for process data to ensure compliance with specifications, demands placed on systems’ accuracy are going up.

In other words, off-the-shelf equipment can be used for run-of-the-mill manufacturing. But to remain competitive in the future, a plating or anodizing firm needs to invest in up-to-date control systems, and perhaps also a qualified assessment of what its needs are likely to be in the foreseeable future. ■

FUNDAMENTALS OF STACK TESTING



By Peter J. Paine

Air pollution is not a new phenomenon. There are several natural forms of air pollution going back to antiquity such as volcanic eruptions which put large amounts of fine dust, ash, cinder, and gases into the atmosphere. The eruption of Mt. Vesuvius outside Naples, Italy, in AD 79 was recorded by the Roman historian Tacitus.

Historical references to air pollution can be found in English history with the introduction of “sea coal” in 11th Century England. Use of sea coals (so called because the locations of out-cropping coal seams were near the sea) gave rise to mounting nuisance complaints of smoke and gas. At this time, the main fuel was wood. However, with the discovery and use of coal, the smoke and fly ash problem (these were the two “main” air pollutants at that time) continued to worsen. This was especially the case during the Industrial Revolution which started in England in the late 18th Century and continued into the mid-19th Century.

The Industrial Revolution in England (and industrial development in other countries) – and the metallurgical and technological developments that were made during these important years – was fueled entirely by coal. In the early 1900s, Dr. Voeux, an English physician, coined the term “smog” to describe the combination of smoke and fog which he concluded was the cause of respiratory issues with his patients.

As coal was gradually replaced by petroleum, the soot and fly ash problems from coal were replaced by new species of pollution such as oxidants, peroxides, ozone, and various hydrocarbon reaction products (photochemical pollution).

By the early 1970s, and in recognition of and response to potentially worsening environmental issues, both the USA and Canada had formed federal environmental agencies: The US EPA (formed in 1971) and Environment Canada (formed in 1972), respectively. Their task was to develop regulations to control pollutants released by various industrial sectors and to set limits to environmental (air, water and soil) pollution.

FIGURE 1: TYPES OF AIR POLLUTANTS.

Types of Pollutants

Conventional – SO₂, NO_x, CO
 Volatile – VOCs, VC, Freons, BTEX
 Semi-volatile – Dioxins, PCBs, CBs, PAHs
 Particulate – TPM, PM_{2.5}, PM₁₀
 Metals – Hg, Pb, Zn, Cr, Ni, As

One manner with which to regulate industrial air pollution from stationary sources is to find out how much is being released by that specific industry. One way to do this is to perform stack testing for the contaminant in question. Stack testing is the process whereby a

FIGURE 2: STACK TESTING STEPS.

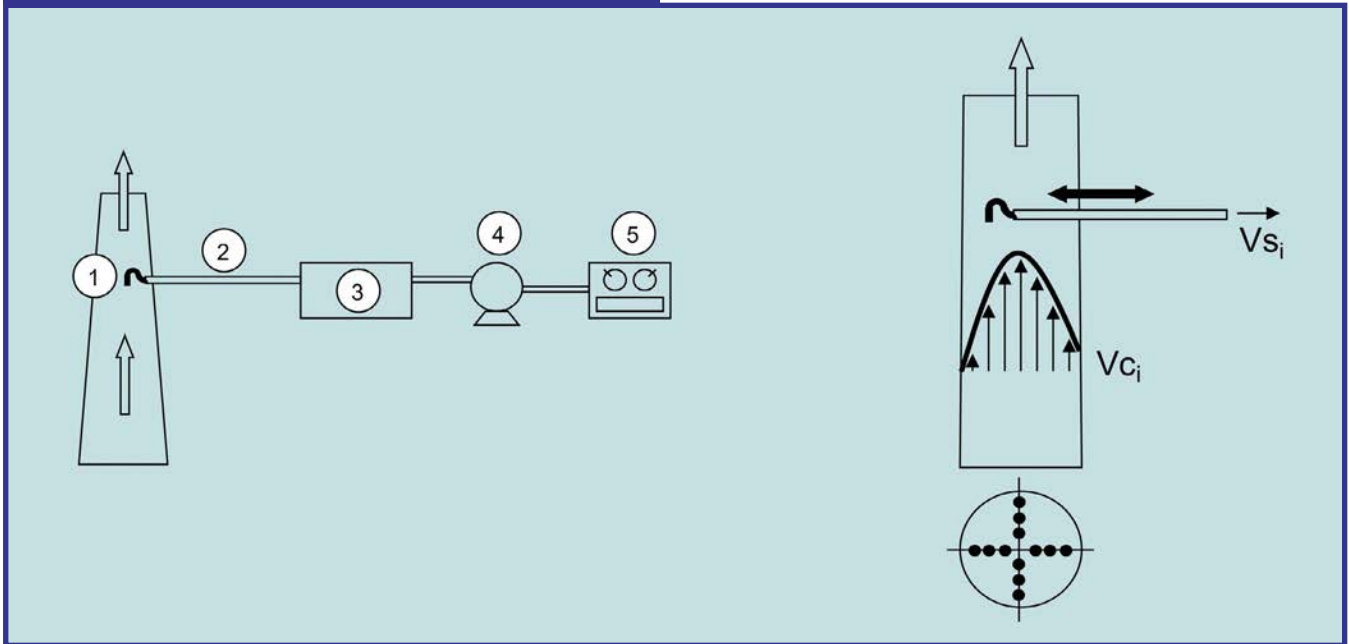

representative sample of a given substance is collected from a stack in order to comply with a given “requirement” for that substance, be it a (federal/provincial) regulation or a (provincial) permit.

The substance in question may be a regulated metal such as lead (e.g. Secondary Lead Smelting Regulations, 1978), mercury (e.g. Mercury cell chlor-alkali Release Regulations, 1978) or hexavalent chromium (e.g. Chromium Electroplating Regulations, 2009); or a Gas (e.g. landfill gas – methane); or dioxins and furans (from municipal incineration). Figure 1 summarizes some of the different types of regulated pollutants.

What is Stack Testing?

Performing a stack test for compliance or regulatory purposes involves the collection and analysis of an air sample. This incorporates four basic processes:

- Collecting the substance in the air sample which is flowing in the stack
- Transporting the air sample collected from the stack
- Measuring the volumetric flowrate of the sample collected
- Determining the amount of substance in the sample which was collected from the air sample

These steps are shown in a general configuration in Figure 2.

The sample is collected from the stack in a stainless steel or glass nozzle (1) whose opening is perpendicular to the air flow in the stack. The sample is then moved from the stack via the probe (2) to the impingers (3). At the impingers, the sample from the stack is now collected (fixed) in a chemical solution. The air tight pump (4) moves the sample through the train. The total air flow during the sampling run is recorded by the dry gas meter (5).

The sample collected in the impinger is then analyzed for the substance in question (which gives a weight of the substance) and the volume of air from which this weight of sample was collected is obtained from the gas meter. Sample weight divided by volume of

air collected during the sampling run gives a concentration (mg/cubic meter, micrograms/cubic meter) of the substance in the stack air at the time of sampling.

Sampling is accomplished by withdrawing a convenient amount of gaseous and particulate material using a sampling train. The basic components of a typical sampling train consist of:

- Extraction: sampling nozzle
- Transport: sampling probe
- Separation: collection devices (impingers)
- Moving: gas mover (airtight pump)
- Metering: gas metering device (dry gas meter)

The problem or complexity involved with stack testing is that in order to obtain a truly representative sample from the stack or duct being tested the representative sample must:

Have a gas density equal to the average gas density of the cross-section of the stream.

Contain a pollutant concentration equal to the average pollutant concentration of the cross-section of the parent stream.

Have no chemical changes in the pollutant collected from the gas sample that will alter the nature or composition from that which existed at the point of extraction during the sampling period.

Components of the Sample Train

The nozzle is inserted into the stack air flow and is the point at which the sample enters the sample train. The nozzle is made of stainless steel, quartz or glass (for low temperature stack air and for metals such as chromium). Figure 3 shows a schematic of the nozzle.

The probe consists of the liner and a sheath. The sheath may be heated, depending on the sampling requirement, to prevent sample condensation before reaching the impingers. The probe essentially ensures the air sample gets to the impingers safely and unchanged by loss caused by condensation. For metals sampling the liner is

FIGURE 3: THE NOZZLE.

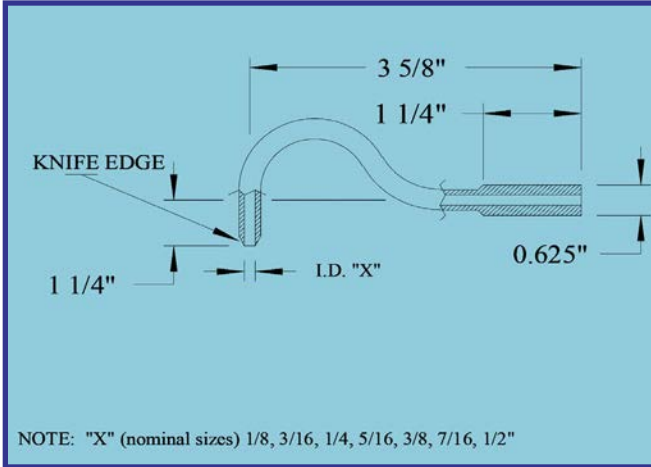

FIGURE 5: A COMPLETE STACK TESTING TRAIN FOR PARTICULATES.

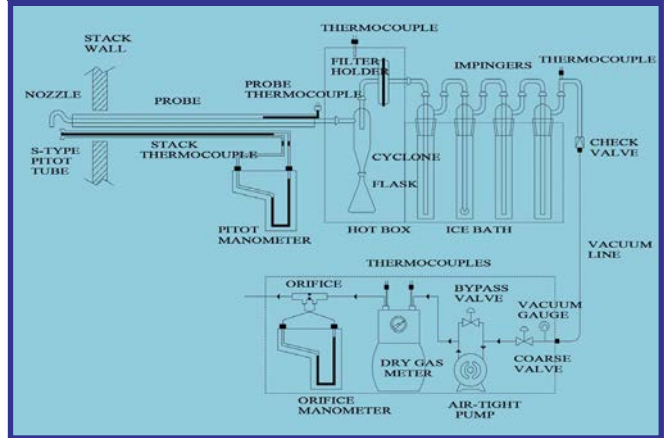
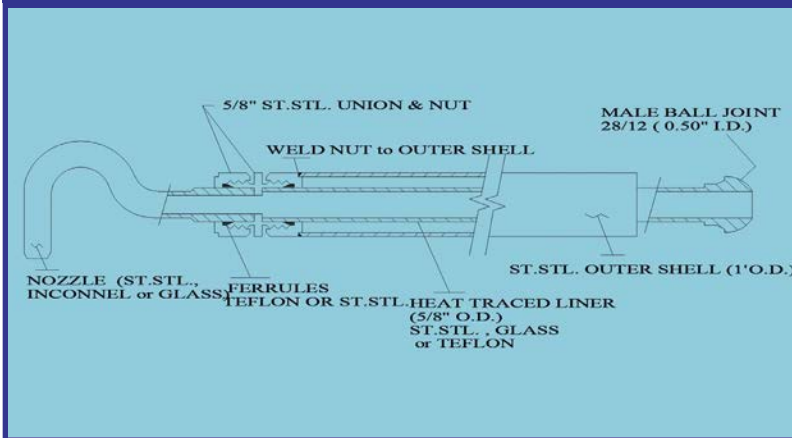

FIGURE 4: THE PROBE (LINER AND SHEATH).



quartz or glass. Figure 4 shows a schematic of the probe.

A complete stack testing train for particulates is shown in Figure 5. Modifications are made to this train depending on the parameters to be sampled.

Location of Sampling Site and Traverse Points

When sampling a stack, the location of the sampling site and location of traverse sampling points are important to optimize the extraction of a representative sample. The ports on the stack (where the probe enters the stack) can be established during the stack test if none exist. The traverse points are located on the stack diameter on perpendicular axes.

Select a site in a straight section of stack or duct located at least eight stack or duct diameters downstream and two stack or duct diameters upstream of any flow disturbance (e.g. a bend, an expansion, a contraction, visible flame, junction, or stack exit).

In circular stacks or ducts, at least two sampling ports with a 90-degree separation are required. This means that sampling is done on two perpendicular axes.

When the sampling site is located at least eight diameters down-

stream and two upstream from a flow disturbance, the required minimum number of traverse points for a circular or rectangular cross section is determined from Figure 6.

The minimum number of traverse points for velocity sampling is shown in Figure 7.

Once the total number of traverse points has been determined, the location of where the nozzle is to be placed (i.e. traverse points) has to be made. Locate the sampling points on the traverse from the table in Figure 8. This will give you the placement of the sampling nozzle from the stack wall.

An example calculation has been made for a seven-foot diameter stack and shown in Figure 9. A summary of traverse locations is shown for circular and rectangular cross section stacks in Figure 10 based on the example calculation of Figures 7, 8 and 9.

FIGURE 6: MINIMUM NUMBER OF TRAVERSE POINTS FOR PARTICULATE SAMPLING WITH FLOW DISTURBANCE.

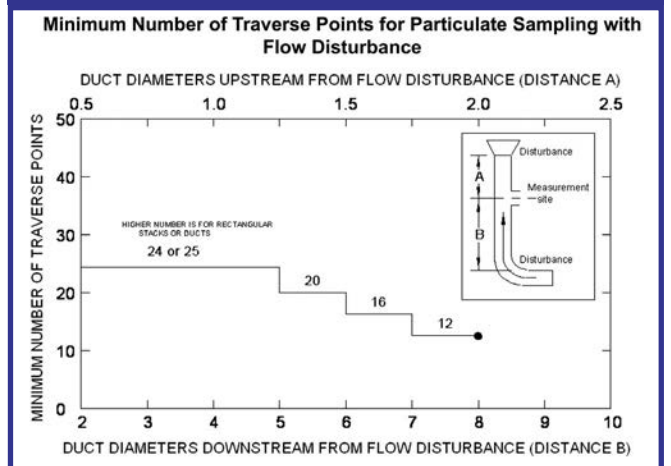



Palm Commodities International, LLC is a chemical manufacturing and distribution business based outside of Nashville, in LaVergne, TN. Palm produces high purity liquid nickel concentrates such as nickel bromide, nickel chloride, nickel sulfamate and nickel sulfate solutions. Palm also offers toll blending, contract manufacturing and private labeling services for liquid chemical

A large graphic featuring laboratory glassware with colored liquids, piles of colorful powders, and stacks of metal anodes. Overlaid on the image are three white boxes with the text "Chemicals", "Metals", and "Crystals & Salts".

Chemicals

Metals

Crystals & Salts

Producer and supplier of high quality chemicals, metal anodes, equipment & supplies to the surface finishing industry for more than 35 years. Palm should be your first choice.

PALM 
a umicore company

615-641-1200 • www.palminc.com • 1717 JP Hennessy Dr. LaVergne, TN. 37086

products. In addition, Palm distributes more than 150 chemical and metal products to industries as diverse as the electroplating, surface finishing, glass, ceramic, catalyst, and water treatment markets.

Since 1978, Palm has developed a reputation of producing and selling high-quality products and delivering outstanding customer service. Palm solves problems for our customers while looking for innovative ways to add value.

To learn more please visit us at www.palminc.com

FIGURE 7: MINIMUM NUMBER OF TRAVERSE POINTS FOR VELOCITY MEASUREMENT WITH FLOW DISTURBANCE.

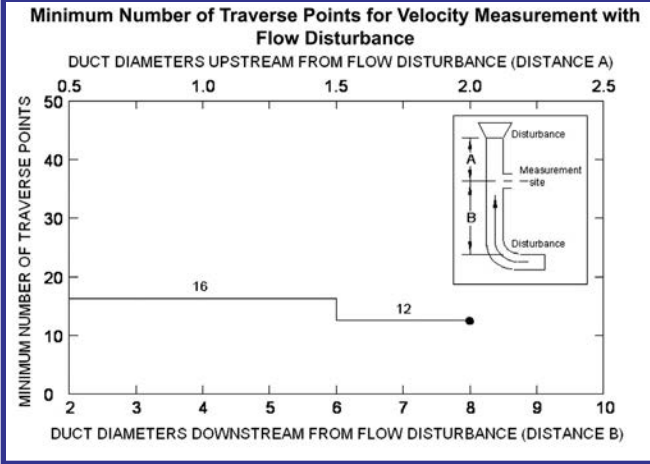

FIGURE 8: PERCENT OF STACK DIAMETER FROM INSIDE WALL TO TRAVERSE POINT.

Traverse Point Number on a Diameter	Percent of Stack Diameter from Inside Wall to Traverse Point																								
	Number of Traverse Points on a Diameter																								
1	14.6	6.7	4.4	3.3	2.5	2.1	1.8	1.6	1.4	1.3	1.1	1.1													
2	85.4	25	14.7	10.5	8.2	6.7	5.7	4.9	4.4	3.9	3.5	3.2													
3		75	29.5	19.4	14.6	11.8	9.9	8.5	7.5	6.7	6	5.5													
4			93.3	70.5	32.3	22.6	17.7	14.6	12.5	10.9	9.7	8.7	7.9												
5				85.3	67.7	34.2	25	20.1	16.9	14.6	12.9	11.6	10.5												
6				95.6	80.6	65.8	35.5	26.9	22	18.8	16.5	14.6	13.2												
7					89.5	77.4	64.5	36.6	28.3	23.6	20.4	18	16.1												
8						96.7	85.4	75	63.4	37.5	29.6	25	21.8	19.4											
9							91.8	82.3	73.1	62.5	38.2	30.6	26.1	23											
10								97.5	88.2	79.9	71.7	61.8	38.8	31.5	27.2										
11									93.3	85.4	78	70.4	61.2	39.3	32.3										
12										97.9	90.1	83.1	76.4	69.4	60.7	39.8									
13											94.3	87.5	81.2	75	68.5	60.2									
14												98.2	91.5	85.4	79.6	73.9	67.7								
15													95.1	89.1	83.5	78.2	72.8								
16														98.4	92.5	87.1	82	77							
17															95.6	90.3	85.4	80.6							
18																98.6	93.3	88.4	83.9						
19																	96.1	91.3	86.8						
20																		98.7	94	89.5					
21																			96.5	92.1					
22																				98.9	94.5				
23																					96.8				
24																						98.9			

Isokinetic Sampling

For particulate sampling or sampling micron-sized particles, it is necessary to sample at isokinetic rates. In isokinetic sampling, the velocity of gas entering the nozzle is the same as the velocity of the gas in the stack at that point so as to obtain representative samples. A large error can be introduced if sampling at other than isokinetic velocities. Sampling at greater or less than the isokinetic rate causes a larger or smaller volume of gas to be withdrawn from the stack than the nozzle area would account for.

Methods of Estimating Releases

There are several other methods available for estimating stack releases in addition to stack testing. Some of the methods available to industry are:

- Material balance (mass, energy)
- US EPA AP 42 emission factors
- EEEquipment efficiency
- Continuous emission monitoring

FIGURE 9: AN EXAMPLE OF TRAVERSE CALCULATIONS.

Traverse Calculations: Example

Location of Traverse points from stack wall for a 7 ft diameter (84 inch) stack	84 ins	4.4%	3.7 ins
	84	14.7%	12.35
	84	29.5%	24.78
	84	70.5%	59.22
	84	85.3%	71.65
	84	95.6%	80.3

FIGURE 10: LOCATION OF TRAVERSE POINTS FOR CIRCULAR AND RECTANGULAR CROSS SECTIONS.

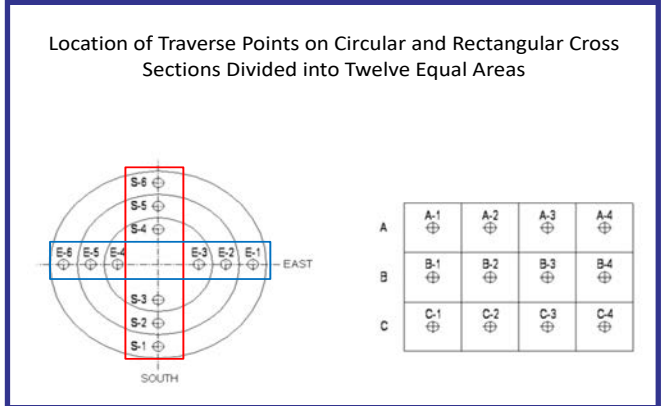

- Remote sensing
- Visual observation (Ringleman charts, opacity)
- Senses (e.g. odor)

Conclusions

Stack sampling is a somewhat more complex process than wastewater sampling due to the nature of a gas over a liquid.

Several estimation methods are available to industry for compliance purposes in addition to stack testing or for NPRI reporting.

Several pollutants are amenable to stack testing but some are easier to assess by other methods.

Sample location (eight downstream and two upstream rule) is important in establishing the number of traverse points.

Traverses on two perpendicular axes and the 8/2 rule determines number of points on each traverse.

Isokinetic sampling is important for particulates and micron-sized particles. ■

Peter J. Paine is CEO of P. J. Paine and Associates. For additional information on stack testing or if you are a chromium plater planning a stack test, contact pjpinc@rogers.com or (613) 884-9029.

STRONGER



Technical
Training



Industry
Support



Regulatory
Advocacy



Online
Resources



Environmental
Stewardship



Networking
Events

TOGETHER

Are you an Electroplater, Anodizer, Surface Finisher or Supplier?

The surface finishing industry plays a vital role in the Canadian and global economies. In Canada alone, it is responsible for \$3.5 billion in economic output. It is also one of the most regulated industries in Canada.

The Canadian Association for Surface Finishing is Canada's only industry association for electroplaters, anodizers and other surface finishers. It doesn't matter if your business is big or small, we can help!

Join CASF Today!

Visit CASF.ca

For more information contact:
Graham Douglas, CASF President
(416) 435-8992
gdouglas@uba.ca

C  **SF**

Canadian Association for Surface Finishing



The Surface Finishing Industry in Canada

Economic Impact Study – Introduction and Background

The Canadian Association for Surface Finishing (CASF) engaged Orr & Boss to conduct an Economic Impact Study of the Canadian Surface Finishing Industry. The study evaluated numerous economic factors and data sets including the size of the surface finishing industry in Canada, jobs created, GDP impact, and taxes generated.

The Surface Finishing Industry was defined as the entire surface finishing market including both Job Finishers and Captive Finishers. Also included were raw material suppliers, professional service providers, and capital equipment providers since the surface finishing generates economic activity from these sectors as well. The report investigated all types of surface finishing including: Anodizing, Antiquing, Electroplating, Electropolishing, Etching, E-Coating, Hot Dip Galvanizing, Polishing, Powder Coating, Physical Vapor Deposition, and Electroless Finishing.

Summary of Results

- **Surface Finishing Output:** The Total Output of surface finishers in Canada is estimated to be \$3.5 billion. This is the revenue of the surface finishing companies themselves; those companies actually applying the surface finish to the metallic or non-metallic substrates.
- **Supplier Output:** In addition to the above, the industry generates \$930 million of output by suppliers to the industry. The raw materials used in the industry generate \$723 million of output. Raw materials include both commodity and proprietary raw materials (I.e. Metals, chemicals, etc.). In addition to the \$723 million of raw materials, there is \$206 million of spending on other suppliers to the industry including professional service suppliers and capital equipment suppliers.
- **Employment:** Total employment in the industry is estimated to be 17,198. This includes both employees at the surface finishers themselves and the suppliers to the surface finishers.

- **Salary & Wages:** Total salary and wages in the industry are estimated to be \$705 million. The average wage and salary are about 26% higher than the Canadian average reflecting the higher skill level required as well as the relatively high productivity of the industry.
- **Total GDP Impact:** It is estimated that the total GDP impact of the surface finishing industry in Canada is \$1.3 billion.
- **Taxes:** The industry generates annual estimated Federal and Provincial Tax Revenue of \$447 MM.
- **Provincial Impact:** Most of the surface finishing industry is centered in Ontario where it is estimated that 57% of the economic activity occurs. Alberta and Quebec account for 19% and 13% of the economic activity, respectively.
- **Industrial Coatings:** In addition to the above cited economic impacts, factory applied industrial coatings (I.e. Powder/ Liquid Coating), which are an adjacent and overlapping industry to the surface finishing industry have a significant additional Economic Impact. Industrial Coatings contribute a Total Economic Output of \$3.0 billion, generate 21,240 jobs, contribute \$1.1 billion to GDP, and generate an estimated \$428 million of additional taxes.
- **Total Surface Finishing and Industrial Coatings Impact:** The combined Surface Finishing and the Industrial Coatings market results in the following economic impacts across Canada per annum:
 - Output of \$6.5 billion
 - Wages of \$1.4 billion generated
 - Jobs created of 38,438
 - GDP Impact of \$2.5 billion
 - Total Taxes of \$876 million collected

To receive a free digital copy of the study, please contact Graham Douglas, CASF President, gdouglas@uba.ca or visit www.CASF.ca





Connecting **Chemistry**

**BUILDING
A BRIGHTER
WORLD**



Globalization and ever more stringent regulation confront the manufacturing industry each year, presenting greater and greater challenges. Brenntag Canada recognizes that the specialty chemicals market does not have to be so complicated, however – we aim to make all aspects of chemical distribution less complex for our customers and suppliers.

Through a dedicated and experienced team of technical experts and sales agents, Brenntag Canada offers tailor-made solutions to each customer's individual needs and business challenges with a degree of professionalism that few of our competitors can match. From providing advice on improving formulations, to devising innovative supply-chain solutions, to sourcing specialty ingredients, Brenntag Canada delivers products and services which put our customers and suppliers a step ahead of the competition.

We at Brenntag demonstrate that the distribution of chemicals and ingredients is not just a business for us. It is an attitude. And our passion is to be the best partner connecting you as our customers and suppliers in local markets worldwide.

Brenntag Canada Inc.
Corporate Office
43 Jutland Road
Toronto, ON M8Z 2G6
Phone: (416) 259-8231
(800) 387-7324
Fax: (416) 259-5333
email: sales@brenntag.ca

www.brenntag.ca

About Brenntag:

Brenntag is the global market leader in chemical and ingredients distribution. We connect our suppliers and customers in value-adding partnerships. Our almost 17,500 employees provide tailor-made application, marketing and supply chain solutions. Technical and formulation support, market, industry and regulatory expertise as well as advanced digital tools are just some examples of our services that are aiming to create an excellent customer experience.

Our full-line portfolio comprises specialty and industrial chemicals and ingredients of a world-class supplier base. Building on its long-standing experience, unmatched global reach and local excellence, Brenntag works closely alongside its partners to make their business more successful. We are committed to contribute towards greater sustainability in our own business and the industries we serve, and to achieve sustainable profitable growth. Headquartered in Essen (Germany) and with regional headquarters in Philadelphia, Houston and Singapore, Brenntag operates a unique global network with more than 640 locations in 77 countries. The company generated sales of EUR 12.8 billion (USD 14.4 billion) in 2019. Brenntag shares are traded at the Frankfurt Stock Exchange (BMR).





SAMES KREMLIN LAUNCHES AIRLESS PUMPS, PACKAGES

SAMES KREMLIN announced the release of its new Azur Airless Protective Coatings pumps and packages in January, with a goal of expanding into the protective coatings market.

The new pump range will be available in two different versions; the 52C225 and the 72C160.

SAMES KREMLIN says features include:

Atomization: The air motor is pulsation-free which ensures stable fluid delivery in order to achieve consistent film build. In addition, the SFlow spray gun is embedded with dual diffuser technology to achieve a quality finish with less rework.

Operation in harsh and intensive conditions: Minimized icing potential, high suction power capacity and an air motor that does not stall.

Simple maintenance: A reduced number of components means maintenance minimized.

Comfort of use: With a quiet air motor, gun ergonomics and maneuverability, the goal is to maximize the comfort for the operator (soft trigger pull for less finger fatigue and 360-degree swivel fitting).

www.sames-kremlin.com

CARLISLE INTRODUCES NEW SHOT METER DISPENSING SYSTEM

Carlisle Fluid Technologies recently introduced a new shot meter-based dispensing system.

The company says the system is “extremely accurate”, easy to install and can be used for a wide range of single component sealant and adhesive applications including mastics, silicones, greases, epoxies, acrylics, urethanes and PVCs for non-automotive robotic dispensing systems.

“The new i-Flow GP is a complete dispensing system that provides accurate, repeatable dispense performance and improved process control,” says Carl Penttila, Carlisle Fluid Technologies Product Manager. “The unit also provides easy integration with most fieldbus protocols including ProfiNet, Ethernet/IP and DeviceNet”.

Carlisle says it is excited about the new line, which also includes sealant and adhesive products, all of which it says expand the company’s capabilities.

www.carlisleleft.com



Binks iFlow GP
Shot Meter
Dispensing System



LAMBIENT LAUNCHES COMPOSITES CURE MEASUREMENT SOLUTION FOR AC AND DC

Lambient Technologies LLC, which offers measurement solutions for the curing of advanced composites, has released the LT-440 Dielectric Channel. Lambient says it is the first composites cure measurement solution to combine AC and DC measurement capabilities.

“By adding DC to our longstanding AC measurement capabilities, Lambient can now provide accurate data on the cure of extremely resistive materials, such as silicones,” the company says.

For users who currently rely on alternative DC measurement solutions, the LT-440 provides the added toolset of AC measurement. This allows users to measure cure in applications deploying barriers like vacuum bags and release films, where DC measurements won’t work. DC users gain the ability to use AC measurements to more accurately follow the entire cure.

www.lambient.com

TENNANT COATINGS LOOKS TO ELEVATE EPOXY FLOORING

Tennant Coatings, Inc., manufacturer of commercial, institutional and industrial coating systems for concrete floors, has launched its new Tennant Decorative Stone Slurry System.

“The epoxy flooring advancement features a unique luxury aesthetic with stunning color saturation and striking optical depth, furnishing design professionals with a nearly unlimited new palette for shaping the ambiance and character of interior spaces,” the company says.

Compared to traditional decorative resin floors, the new system reduces downtime, enabling facilities’ day-to-day operations to resume faster, Tennant says. It adds that an easy-install cove base integrates seamlessly into the floor surface to minimize joints, seams and 90-degree angles to enhance cleanability and pathogen control. Tennant Coatings’ high performance resins ensure optimal chemical and abrasion resistance while minor surface damage can be repaired with almost undetectable results, the company says.

The brand also offers low-emissions, LEEDv4-certified epoxy and urethane systems, as well as vinyl ester coatings and concrete polishing products.

“The new Tennant Decorative Stone Slurry System takes epoxy flooring aesthetics, performance and installation to a new level and has received accolades from our authorized contractor network,” says Don Andrews, VP of Tennant Coatings. “Our experienced installers recognize the competitive advantages offered by the system, in terms of faster floor and cove installation, outstanding performance and ‘invisible’ repairs. We’re excited to see this innovative solution installed in pharmaceutical and education facilities, among others, in the coming months.”

www.tennantco.com

BASF INTRODUCES PORTFOLIO FOR PROTECTIVE WOOD GRAIN ENHANCEMENT

BASF has developed a new portfolio for water-based systems to protect and highlight wood while meeting sustainability needs.

The Joncryl 953X portfolio includes five straight acrylic dispersions. All of them are multi-purpose and fine-particle sized.

BASF says the products fulfill key performance characteristics for wood coatings such as resistance to chemicals, scratch resistance, hardness, and blocking resistance as well as high wet transparency and in-can clarity. Additionally, customers can choose products with low to zero co-solvent demand.

“The interest in industrial wood coatings with improved appearance is gaining momentum,” says Dr. Nick Gruber, Head of Industry Management Resins for Furniture & Flooring at BASF. “Look and feel are increasingly important as buying factors for wooden surfaces.

“We are pleased that we can offer our customers a product range that combines excellent grain enhancement with performance and sustainability. The new range comprises different products, all of them designed to have their particular strengths so that they can meet different customer needs, allowing customers to select the most appropriate product. This is a great addition to our portfolio.”



The Joncryl 953X portfolio includes:

- Joncryl 9530: Grain enhancement and chemical resistance
- Joncryl 9531: Balance between blocking and chemical resistance
- Joncryl 9532: Blocking, chemical and scratch resistance
- Joncryl 9533: Early blocking resistance and zero percent co-solvent demand
- Joncryl 9534: Blend partner for enhancing blocking resistance and hardness

www.basf.com



FRX POLYMERS DEVELOPS WATER-BASED NON-HALOGENATED DISPERSION FOR TEXTILE COATINGS

FRX Polymers Inc. has announced the development of Nofia W2000 EX water-based dispersions for use in the production of low volatile organic compound (VOC) water-based textile coatings.

Coated textiles are utilized in various markets including automotive, aerospace, agricultural, industrial, healthcare, sports, and defense. They deliver a range of superior properties including flame retardancy (FR), waterproofing and antimicrobial performance.

In the last few years, water-based coatings have grown at a double-digit rate in the textile arena because of their ability to reduce air pollution and exposure to solvents used in solvent-based coatings. An unmet need in water-based coatings has been the ability to offer flame retardancy with a robust halogen-free solution, FRX says.

Nofia W2000 EX Dispersion – currently available for qualification trials – is transparent and has a 60 percent solid content and less than a 400-nanometer particle size. It is compatible with various water-based polymers including polyurethane dispersions used in textile coatings and synthetic leather applications, FRX says, and when added to PUD coatings, Nofia W2000 EX forms a fully transparent film with low haze and soft touch and feel.

The company says in halogen-free tents/tarps and fireproof clothing, Nofia W2000 EX Dispersion does not alter the coating to be seamlessly welded and passes all high-water pressure resistance tests as well as the jungle humidity test. The resulting products pass flame-retardant tests such as CPAI-84 (Canvas Products Association International). Nofia W2000 EX-based coatings also meet ASTM 6413 (vertical burn test for flame resistance of textiles).

In automotive synthetic leathers, Nofia W2000 EX-based coatings meet relevant automotive fire safety standards as well as new total VOC and fogging standards established by major global automotive suppliers as well as the new Chinese GB/T 27630-201X standard, FRX says. In home furnishings, Nofia W2000 EX provides a halogen-free flame-retardant solution for synthetic leathers used in home furniture, meeting BS 5852 Crib 5 standards while maintaining good touch and feel.

www.frxpolymers.com

KERNOW FLOORSHARK ACHIEVES ANTI-SLIP R10 RATING FOR FLOOR GRAPHICS

Kernow Coatings' recently launched FloorSharK Dry Toner has successfully passed the R10 slip test after being tried and tested on a Xeikon 3500 digital press. The two companies have been involved in a rigorous testing program to achieve the R10 anti-slip rating for floor graphics.

"Our new FloorSharK Dry Toner has performed outstandingly on the Xeikon 3500," says Hendrik De Backer, Sales Manager EMEA at Kernow Coatings. "We are delighted with the results... In these challenging times, diversification and adaptation are key. We are excited to be able to introduce a unique market-leading product that's been tried and tested and will open doors for more applications."

FloorSharK Dry Toner is a textured white R10 slip-resistant PET film that is receptive to dry toner print, with an optimized pressure-sensitive adhesive for floor graphic applications. It is available in 500 mm or 330 mm widths. With its sharkskin coating, toner bonding and scratch-resistant properties, it offers a durable and safe surface even on short-pile carpet tiles.

"This successful cooperation with Kernow Coatings opens up greater opportunities for our customers and meets the recent unprecedented and necessary demand for socially distanced floor signage," says Xeikon's Segment Director for Graphic Arts, Dimitri Van Gaever. "Now, with the new FloorSharK with R10 rating, our customers can confidently print non-slip, resilient and creative floor decals to meet demand. And thanks to the unique properties of this material, no post-press lamination is required, saving a significant amount of time and cost in the process."

www.kernowcoatings.com





ROSS MIXES IT UP WITH DOUBLE CONE TUMBLE BLENDERS

ROSS says its new Double Cone Tumble Blender (model DCB) is designed for large-scale blending of free-flowing solids in laboratory, pilot or production sizes. Minor and micro ingredients are thoroughly distributed throughout the batch more gently than in the more common V-shaped geometry without damaging fragile or sensitive components, the company says. Rated for vacuum up to 29.5" Hg, the jacketed 75-cubic foot blender heats and dries product efficiently as it is being blended. Other features include gas purging capability, a 16-inch pneumatically operated discharge valve, five-passage rotary union, explosion-proof brake motor, and PLC controls. www.mixers.com

CARLISLE INTRODUCES NEW SHOT METER DISPENSING SYSTEM

Carlisle Fluid Technologies recently introduced a new shot meter-based dispensing system.

The company says the system is "extremely accurate", easy to install and can be used for a wide range of single component sealant and adhesive applications including mastics, silicones, greases, epoxies, acrylics, urethanes and PVCs for non-automotive robotic dispensing systems.

"The new i-Flow GP is a complete dispensing system that provides accurate, repeatable dispense performance and improved process control," says Carl Penttila, Carlisle Fluid Technologies Product Manager. "The unit also provides easy integration with most fieldbus protocols including ProfiNet, Ethernet/IP and DeviceNet".

Carlisle says it is excited about the new line, which also includes sealant and adhesive products, all of which it says expand the company's capabilities.

The company also launched IntelliSpray System spray foam equipment. The system offers ratio control, remote monitoring and comprehensive reporting systems.

The system also includes the IntelliSpray IS40 Proportioner, ST-1 Air Purge Gun and QuickHeat Hose. It's "one convenient system to get the job done right," Carlisle says.

"Armed with extensive knowledge of material application, the Carlisle Fluid Technologies team leveraged proven technology, and the latest innovations in automation to reinvent the foam system," says Steve Sowada, Director of Sales, Foam product line. "Our team spent more than 5,000 hours in the field, on job sites and personally spraying alongside foam contractors, to design a truly next-generation spray foam solution."

www.carlisleleft.com



FOR MORE NEW PRODUCTS PLEASE VISIT WWW.CFCM.CA

Coatings and inks were the foundation of Andicor's launch into the Canadian specialty chemical market in 2002, and remain a key focus today.

Relationships are key to our business. We work with an exclusive network of leading international suppliers enabling us to expand our product lines to meet the evolving needs of the marketplace. Formulators are assured of quality, cost-effective products such as specialty resins, additives and pigments that meet Canadian industry standards for both regulatory governance and environmental requirements.

Formulators trust Andicor. With experienced sales representatives across Canada and a national warehousing system strategically designed to provide fast, local service to our major industry partners, our reputation is built on our accountability to deliver – every time.

In 2020, Andicor's corporate structure was realigned to better focus the sales efforts within its specialty chemicals and containers divisions. Overall sales responsibility remains with Executive Vice-President John Roeleveld, with Blake Griffiths promoted to National Sales Manager – Containers and Jamie Dinsmore promoted from CASE Market Manager to National Sales Manager – Chemicals. Jamie is now responsible for all chemical sales outside of the Personal Care market. Together with excellent support from one of the world's largest banks, Andicor continues to invest in one of the largest sales teams for a company of its size in Canadian chemical distribution, providing its supplier partners with the professional sales coverage needed to aggressively expand their presence in the Canadian market.

Also in 2020, Andicor was pleased to announce a new exclusive partnership with BRB North America Inc., a full subsidiary of BRB International BV, to distribute BRB's silicone product

portfolio for coatings and inks; personal care; home, car and industrial care; and adhesive, sealants and elastomers markets in Canada. BRB has been working intensively to increase its participation in these markets, so Andicor is very excited for the opportunity to focus BRB's technology, energy and resources to support that effort.

Andicor is pleased to continue its master distribution partnership with the Small Packaging division of Mauser Packaging Solutions, formed from the 2018 merger of BWAY Corp. and Mauser Group. Mauser is the first company of its kind to reliably and sustainably deliver products and services across the entire packaging lifecycle for customers around the globe.

As a proud member of Responsible Distribution Canada, Andicor complies with the RDC RD:2013 Code for its Mississauga, ON, headquarters.

Andicor is also a corporate member of CPCA (Canadian Paint & Coatings Association); TRFA (Thermoset Resin Formulators Association); and ASMAC (Adhesives and Sealants Manufacturers Association of Canada), supporting the organizations that advocate for the industries responsible for Andicor's success for more than 15 years.

Explore our refreshed bilingual website (www.andicor.com) where you can find a complete listing of all the principals and products we offer for each market segment.

ANDICOR SPECIALTY CHEMICALS CORPORATION

590 Abilene Drive
Mississauga, Ontario L5T 2T4
T (905) 795-0911
Toll-Free: 1-866-488-0003

www.andicor.com

WORKING FOR YOU

Andicor Specialty Chemicals is a full-service national distributor of specialty chemicals and packaging products. Our mission is to be a seamless extension of the suppliers we represent, continually working to provide our customers with competitively-priced, globally-sourced, value-added products from market-leading manufacturers.

NEW!
Andicor now
represents
**BRB North
America in
Canada**

Superior customer service

Local warehousing & delivery services

Knowledgeable & responsive sales professionals

- › Alberdingk Boley
- › BRB North America
- › CQV
- › Cathay/Hoover Color
- › FCC
- › Fuji Silysia
- › Heubach/Heucotech
- › HPF The Mineral Engineers
- › Mauser Packaging Solutions
- › Monument Chemical
- › OPC Polymers
- › Orion Engineered Carbons
- › Partners in Chemicals
- › Patcham
- › Rain Carbon
- › Southeastern Performance Minerals
- › TOYOBO



Toll-Free: 1-866-488-0003 • info@andicor.com • andicor.com





GRINDING MEDIA DEPOT®
A Norstone Company

We can help you pick the right media for your application

All types, sizes and shapes

800.726.1366
sales@norstoneinc.com
<http://www.norstoneinc.com>



Conn & Co.

Stainless IT Stainless ITT

The **CONN Blade®s**
Most Efficient & Aggressive Available

UHMW Poly

www.connblade.com
(814) 723-7980



NEWACT
INCORPORATED

SURE-SEAL PLATING DANGLERS

No More Leaky Sleeves!

Two Designs:
Molded & Crimp Over

Custom Manufactured
Vulcanized Sleeve
Molded Directly to Cable

2084 James E. Sauls Sr. Dr. Batavia OH 45103
Call: (513) 321-5177 • 800-914-8392
tvale@fuse.net



To Advertise in this Space!

Contact: Gillian Thomas
1-416-277-1269
gillian.thomas@cfc.ca

AD INDEX

Andicor Specialty Chemicals	69
Azelis Canada	2, 3
Brenntag Canada Inc.	64
CASF Canadian Association of Surface Finishing	62, 63
CONN & Company, LLC	4, 70
CPCA Canadian Paint and Coatings Association	19
Daemar Inc.	15
De Nora Tech, LLC	13
DeFelsko Corporation	11, 45
Dynamix Inc.	25
EMCO-Inortech	17
Erie Powder Coatings	9
Fischer Technology Inc.	48

Gema	39
GENEQ Inc.	7
Katilac Coatings Inc.	42
Kontek Process Water Management	71, 72
MOCAP	21
NewAct Inc.	70
Norstone Inc.	70
Palm Commodities International, LLC	60
Powder Coating Show	10
SAMES KREMLIN Inc.	36
Service Filtration of Canada	54
TTX Therma-Tron-X Inc.	31
Venjakob North America Inc.	51

Kontek Process Water Management is a well-established, privately owned, Canadian company with primary offices and manufacturing facilities located in Burlington, Ontario, Canada.

Kontek was established in 1980 to meet the stringent environmental demands in effluent water compliance throughout the metal finishing industry.

Today, our innovative wastewater treatment systems continue to meet additional emerging market demands. Our mission is to provide our customers with effective systems that meet or exceed compliance with global environmental regulations. Kontek's technology continues to evolve, and we consistently deliver systems to meet your effluent compliance and waste minimization needs.

Our unique company designs, manufactures, installs, commissions, and services wastewater recovery, wastewater treatment, and raw water purification systems for numerous industrial markets. Continual growth and expansion allow us to provide complete in-house fabrication of industrial wastewater management systems that exceed our customers' environmental and water purification objectives. Industries that we currently serve include metal finishing, canning, hydroponics, aerospace, and microchip manufacturing.

Kontek systems can be found in countries across the world, including geographical regions with depleted water resources. These state-of-the-art systems facilitate effluent compliance, metals recovery, waste minimization, closed-loop water recycling, and zero liquid discharge (ZLD).

The Kontek team is comprised of chemists and engineers with years of direct experience in the industries that we serve. Our modular systems are designed with a comprehensive knowledge of our clients' process, chemistry and wastewater composition.

The four cornerstones of Kontek are its process engineering, mechanical engineering, electrical/automation, and service/commissioning departments.

Continuous improvements, along with strong research and development, are constantly implemented to advance each Kontek system's functionality, reliability, and performance.

Recent corporate acquisitions in solids de-watering equipment along with advancements to our membrane technology have heightened our innovation in water purification.

In 2020, Kontek introduced one of the largest systems in the metal finishing industry today, at a brand-new aerospace manufacturing and surface finishing facility overseas. This first-of-its-kind process included Kontek's raw water purification, wastewater recovery, wastewater treatment, and concentrated liquid waste evaporation systems. Each of the modular components of this installation were designed, engineered and manufactured at our Burlington, Ontario facility.

System start-up and commissioning is typically completed on-site, but the global pandemic brought our travel plans to a halt. Due to COVID-19 and the abundance of travel restrictions, this massive undertaking required leading-edge technology to commission the system remotely. Kontek's advanced level of automation, complete with instrumentation and integration capabilities was required.

We met the challenge and installed the first system of its kind to support our newest product offering, the Kontek IntelliKON platform. From anywhere in the world, we are able to monitor, assess, troubleshoot and service IntelliKON clients' systems. This cutting-edge platform also saves a substantial amount on travel, commissioning, and service costs.

For more information on this system or other wastewater recovery, wastewater treatment, raw water purification products, precious metal recovery or any of our services, please contact us at anytime:



Kontek Process Water Management

3250 Harvester Road

Burlington, ON L7N 3W9

Toll Free: +1 877 332 8366

Email: sales@kontekecology.com

Internet: www.KontekWater.com

An ISO 9001:2015 certified company



**UNPARALLELED DESIGN
& PERFORMANCE**

**SOURCE WATER PURIFICATION,
INDUSTRIAL WASTEWATER
TREATMENT & RECOVERY
TECHNOLOGIES**

KONTEK optimizes your industrial wastewater treatment process. Our in-house design/engineering and manufacturing teams create modular designs that reduce site installation costs and provide you with superior service, leading edge technology and the lowest cost of operation.

"...Because it Works!"

KONTEK

PROCESS WATER MANAGEMENT

visit - www.KontekWater.com

